

*Div Eng. Office  
COPY  
LSE/LELEVICH*



# LOCOMOTIVE EQUIPMENT

WESTERN PACIFIC RAILROAD COMPANY  
MECHANICAL DEPARTMENT

# LOCOMOTIVE EQUIPMENT

BOOK NO \_\_\_\_\_ THIS BOOK IS CHARGED TO \_\_\_\_\_  
AND MUST BE RETURNED FOR CORRECTION UPON REQUEST.

RECORD OF REVISIONS.

THIS BOOK IS CORRECTED TO LAST DATE SHOWN

DATE	REMARKS	DATE	REMARKS
12-30-53			

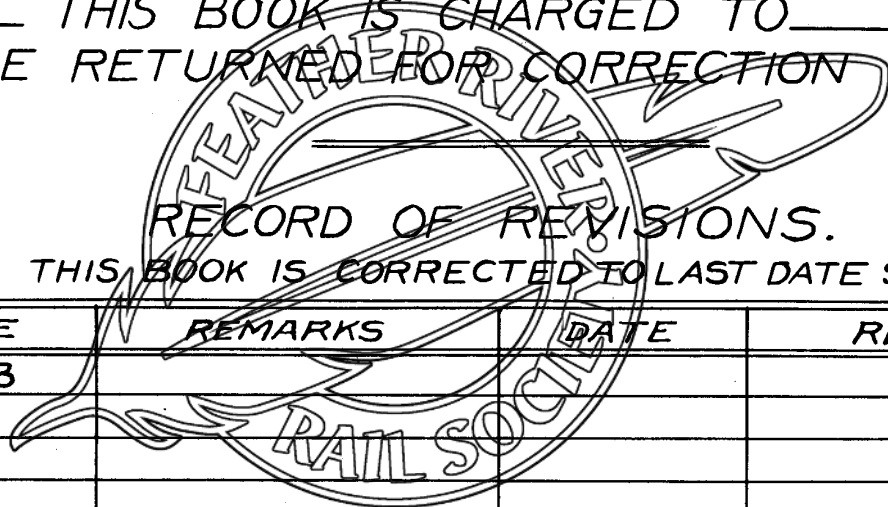

**DIESEL ELECTRIC**

ENGINE ROAD Nos.	No. OF	PAGE	BUILDER	PLACE BUILT	DATE BUILT	BUILDERS ORDER No.	H.P.	REMARKS
501-503	3	2	ELECT. MOT. CORP.	LA GRANGE, ILL.	1939	E-283	600	
504-511	8	3	AMERICAN LOCO. Co.	SCHENECTADY, N.Y.	1942	S-1849	660	
551-558	8	4	AMERICAN LOCO. Co.	SCHENECTADY, N.Y.	1943	E-1540	1000	
559-562	4	5	" " "	" " "	1950	S-3125	1000	
563-564	2	6	" " "	" " "	1951	S-3163	1000	
581-585	5	7	BALDWIN LOCO. WKS.	EDDYSTONE, PA.	1945	S-8445N-C	1000	
601-606	6	8	ELECT. MOT. CORP.	LA GRANGE, ILL.	1952	4168	1200	
701-709	9	9	ELECT. MOT. CORP.	LA GRANGE, ILL.	1952	5197	1500	
710-713	4	10	" " "	" " "	1953	5230	1500	
725-732	8	10-A	" " "	" " "	1955	5407	1750	
801-803	3	11	ELECT. MOT. CORP.	LA GRANGE, ILL.	1947	8002	4500	
804-805	2	12	" " "	" " "	1950	6043	4500	
901-903	3	13	ELECT. MOT. CORP.	LA GRANGE, ILL.	1941	E-411	5400	
904-906	3	14	" " "	" " "	1943	E-555	5400	
907-912	6	15	" " "	" " "	1944	E-635	5400	
913-921	9	16	" " "	" " "	1950	3006	6000	
922-924	3	17	" " "	" " "	1951	3040	6000	
851-853	3	20	BUILT BY ALCO - 1924 CONVERTED BY W.P.R.R. 1950					DIESEL TENDERS
T.S. 735	1	18	GEN. ELECT. CO.	ERIE, PA.	1946		380	
T.S. 741-743	3	19	" " "	" " "			600	LOCOS. 741-742 BUILT 1948, LOCO. 743 BUILT 1953

**STEAM**

I-A

ENGINE ROAD Nos.	No. OF	PAGE	BUILDER	PLACE BUILT	DATE BUILT	BUILDERS ORDER No.	REMARKS
21-65	SEE PAGE 7B	101	AMERICAN LOCO. Co.	SCHENECTADY, N.Y.	1909	S-642, S-646	
164-166		102	" " "	" "	1919	S-1287	ORIG. U.V.C. Co. Nos. 86, 87, 88 PURCH. S.H. 9-27
332-336		103	" " "	" "	1929	S-1647	
481-486		104	LIMA LOCO. WKS.	LIMA, OHIO	1943	A-2913	
T.S. 132		105	BALDWIN LOCO. WKS.	PHILADELPHIA, PA.	1923	C-9850	FORMERLY SIERRA R.R. LOCO. No. 32



NOS. 501-503 No. OF LOCOS. 3  
 BUILT-ELECTRO-MOTIVE CORP. 1939  
 SPEC. NO. E.M.C. MODEL SW-1

# DIESEL SWITCHING 8-WHEEL

ROAD CLASS 501  
 SYMBOL S-50  
 FUEL-DIESEL OIL

POWER PLANT  
 1- 600 H.P. DIESEL ELECTRIC  
 ELECTRO-MOTIVE CORP.  
 DIESEL ENGINE MODEL G-567  
 6-8 1/2" x 10" CYLS. V TYPE, 2 CYCLE  
 4-MOTORS ELECTRO-MOTIVE CORP.  
 TYPE D7A VOLTAGE 300-600  
 CONTROL EQUIPT.  
 ELECTRO-MOTIVE CORP.  
 VOLTAGE 64-76.

AIR COMPRESSOR  
 1- GARDNER-DENVER W.X.E.  
 BRAKE EQUIPT.  
 WESTINGHOUSE A.B. CO. 14 FL.

TRACTIVE POWER 50000 LBS.  
 MAX. PERMISSIBLE SPEED 45 M.P.H.  
 MAX. TRACK CURVE 100 FT. RADIUS.  
 AXLE LOAD 50000 LBS.

\* WEIGHTS IN WORKING ORDER  
 ON DRIVERS OVER 200000 LBS.  
 LOCO. TOTAL ACTUAL SCALE WEIGHTS  
 PRESENT OFFICIAL SCALE WEIGHTS ON DRIVERS AND TOTAL  
 AFTER SAND BOXES, ETC. HAVE BEEN REDUCED.

Loco. No.	501	502	503	203140 LBS.	199680	199380
				5-13-41	6-23-41	8-25-41

TOTAL DRY (LIGHT) WEIGHT  
 APPROX. AVG. 191500 LBS.

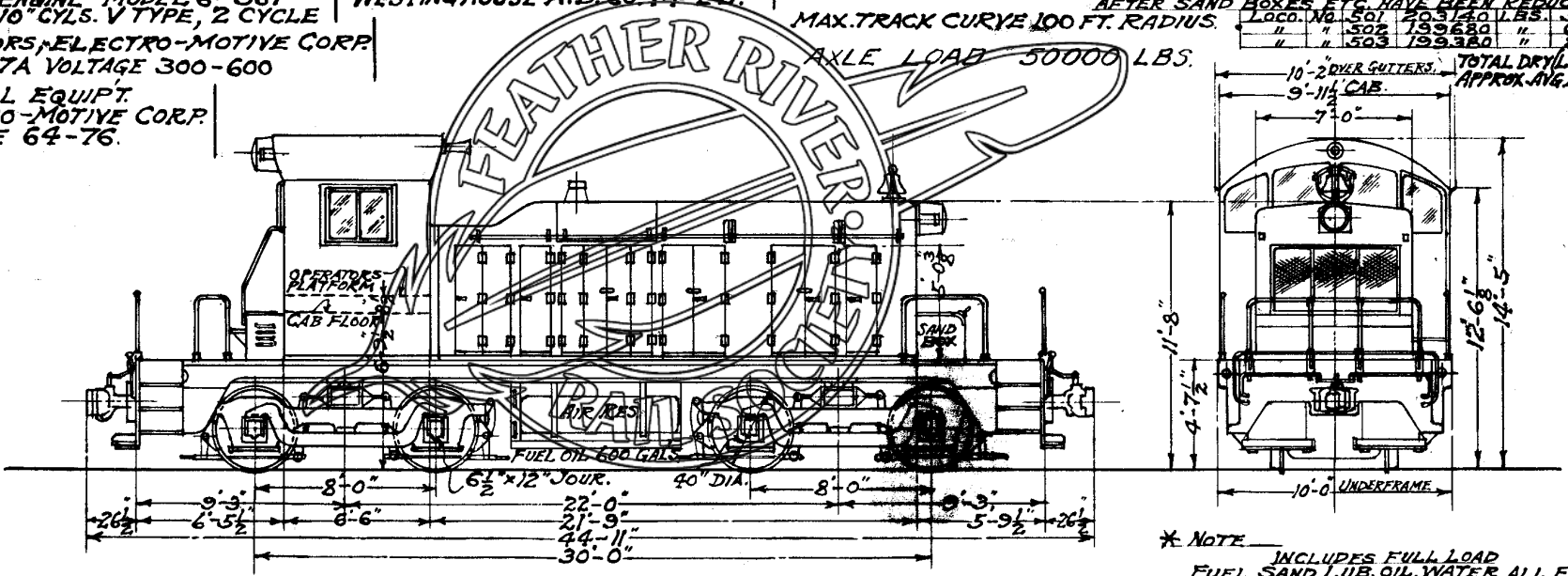

\* NOTE - INCLUDES FULL LOAD  
 FUEL, SAND, LUB. OIL, WATER, ALL EQUIPT.  
 AND 2 MEN IN CAB.

Nos. 504-511 No. of Loco's. 8  
BUILT-ALCO. 1942

# DIESEL-ELECTRIC SWITCHING 8-WHEEL

ROAD CLASS 504  
SYMBOL S-50

SPEC. NO. F-1530.  
POWER PLANT  
1-660 H.P. DIESEL-ELECTRIC UNIT.  
DIESEL ENGINE A.L.CO.  
6-12 1/2 x 13 CYLS. VERT. TYPE, 4 CYCLE  
GENERATORS  
1-G.E. DIRECT-CURRENT TYPE G.T. 552A  
1-G.E. EXCITER TYPE G.M.G. 139-A1  
TRACTION MOTORS  
4-G.E. DIRECT-CURRENT TYPE G.E. 731  
GEAR RATIO 75:16  
CONTROL EQUIPMENT.  
G.E. TYPE P.

AIR COMPRESSOR  
1- WESTINGHOUSE TYPE 3-CD  
BRAKE EQUIPMENT  
WESTINGHOUSE F.L.-14  
CLASP BRAKES.

TRACTIVE POWER 50000 LBS.  
MAX. PERMISSIBLE SPEED 60 M.P.H.  
MAX. TRACK CURVE 50 FT. RADIUS

\* FUEL-DIESEL OIL  
WEIGHTS IN WORKING ORDER:  
TOTAL ON DRIVERS 202000 LBS.  
TOTAL DRY (LIGHT) WEIGHT 188000 LBS.  
AXLE LOAD 50500 LBS.

FUEL-DIESEL OIL 635 GALLS  
LUBR. 88  
ENGINE COOLING WATER 220  
SAND 2700 LBS.

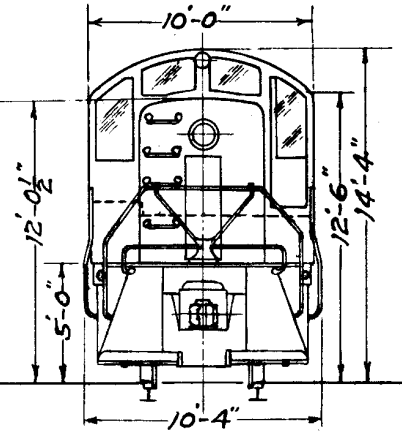
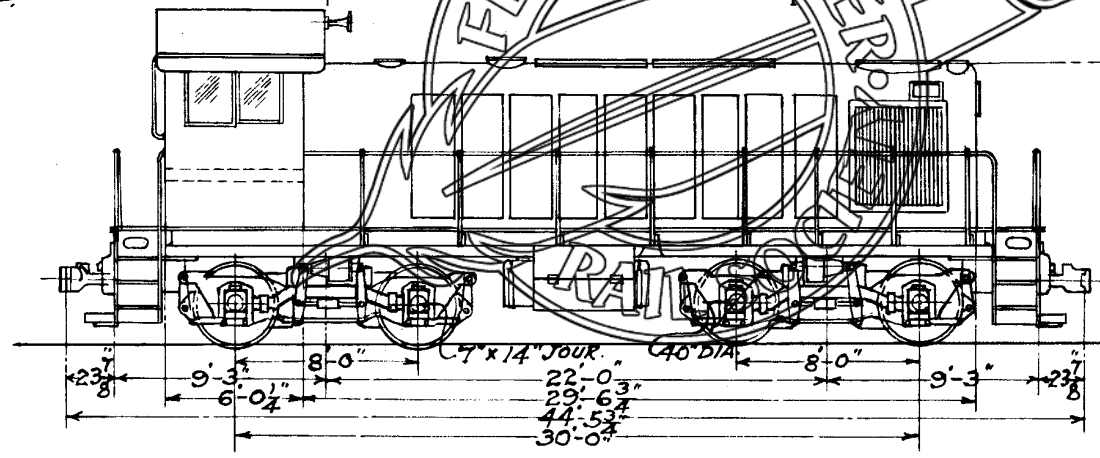

NOTE—  
\* INCLUDES FULL LOAD  
FUEL OIL, LUBR. OIL, WATER, SAND,  
ALL EQUIPT. AND 2 MEN.

R.J.D. 7-42

REV.  
5-7-52  
12 30 53

Nos. 551-558 No. of Locos. 8  
 BUILT-ALCO. 1943.  
 SPEC. NO. E-1540.

# DIESEL-ELECTRIC SWITCHING 8-WHEEL

ROAD CLASS 551  
 SYMBOL S-57

**POWER PLANT**  
 1-1000 H. P. DIESEL-ELECTRIC UNIT  
 DIESEL ENGINE A.L. CO.  
 6-12½x13 CYLS. VERT. TYPE, 4-CYCLE  
**GENERATORS**  
 1-G.E. DIRECT-CURRENT TYPE PG.T.553A  
 1-G.E. EXCITER TYPE G.M.G.139 A2  
**TRACTION MOTORS**  
 4-G.E. DIRECT-CURRENT TYPE G.E. 731C  
 GEAR RATIO 75:16  
**CONTROL EQUIPMENT**  
 G.E. TYPE P.

**AIR COMPRESSOR**  
 1- WESTINGHOUSE TYPE 3-CD  
**BRAKE EQUIPMENT**  
 WESTINGHOUSE EL-14  
 CLASP BRAKES

**TRACTIVE POWER** 57500 LBS.  
**MAX. PERMISSIBLE SPEED** 60 M.P.H.  
**MAX. TRACK CURVE** 50 FT. RADIUS.

**WEIGHT IN WORKING ORDER**  
 TOTAL ON DRIVERS 230000 LBS.  
**TOTAL DRY (LIGHT) WEIGHT** 220100 LBS.  
**AXLE LOAD** 57500 LBS.

**FUEL-DIESEL OIL** 635 GALS  
**LUBR** 88  
**ENGINE COOLING WATER** 240  
**SAND** 2700 LBS.

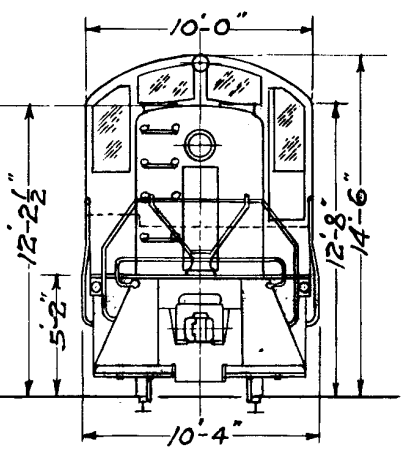
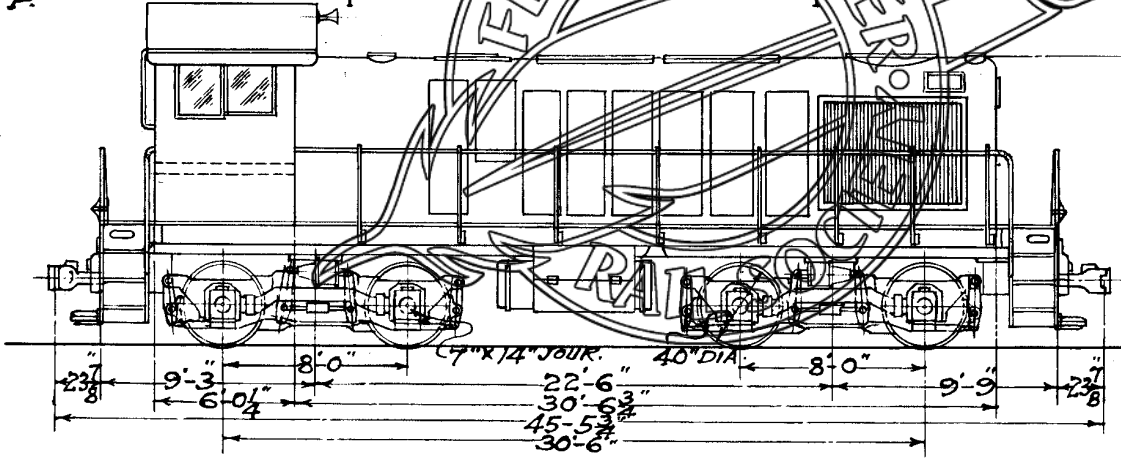
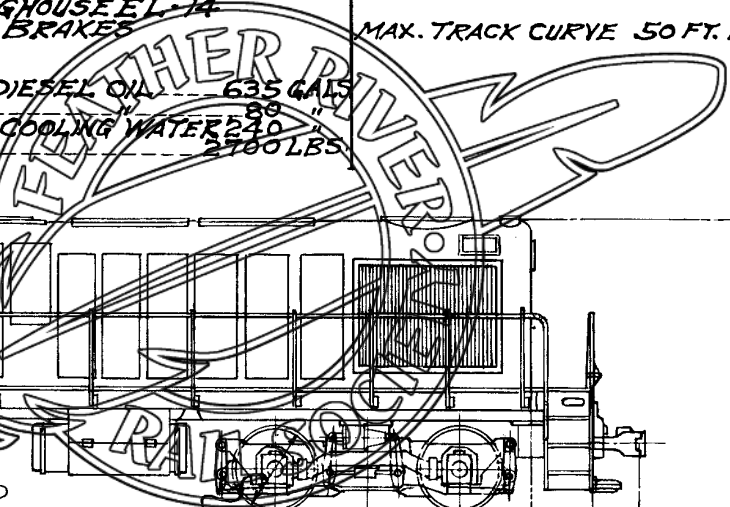

**NOTE:**  
 \* INCLUDES FULL LOAD FUEL  
 OIL, LUBR. OIL, WATER, SAND,  
 ALL EQUIP. AND 2-MEN.

REV.  
 1-30-52  
 12-30-53

R.J.D. 9-43

AFE 50-50

# DIESEL-ELECTRIC SWITCHING 8-WHEEL

ROAD CLASS 559  
SYMBOL S-57

NOS. 559-562 No. OF LOCOS. 4.  
 BUILT BY ALCO. 1950  
 SPECIFICATION No.  
 POWER PLANT:  
 1-1000 H.P. DIESEL-ELECTRIC UNIT  
 DIESEL ENGINE - A.L. Co.  
 6-12 1/2" x 13" CYLS. VERT. TYPE, 4-CYCLE  
 GENERATORS:  
 1-G.E. DIRECT CURRENT TYPE GT. 553-A  
 1-G.E. EXCITER TYPE G.M.G.-139-A2  
 TRACTION MOTORS:  
 4-G.E. DIRECT CURRENT TYPE GE-73  
 GEAR RATIO - 75:16  
 CONTROL EQUIPMENT:  
 G.E. TYPE P SINGLE END  
 MULTIPLE CONTROL EQUIPPED

AIR COMPRESSOR:  
 1-WESTINGHOUSE TYPE 3-CD  
 228 CU. FT./MIN. FULL SPEED 76 CU. FT./MIN.  
 IDLING CAPACITY  
 BRAKE EQUIPMENT:  
 WESTINGHOUSE EL-12 CLASP BRAKES  
 FUEL - DIESEL OIL 635 GALS.  
 LUBRICATING " 80 "  
 ENGINE COOLING WATER 240 "  
 SAND 2700 LBS.

FUEL - DIESEL OIL  
 \*WEIGHT IN WORKING ORDER  
 TOTAL ON DRIVERS 245400 LBS.  
 TOTAL DRY(LIGHT) WT. 221200 "  
 AXLE LOAD 61350 "  
 TRACTIVE POWER 57,500 LBS.  
 MAX. PERMISSIBLE SPEED 60 M.P.H.  
 MAX. TRACK CURVE 50 FT. RADIUS



NOTE:  
 \* INCLUDES FULL LOAD FUEL  
 OIL, LUBR. OIL, WATER, SAND,  
 ALL EQUIP. AND 2 MEN.

FOR DIAGRAM SEE PAGE 4

REVISED  
12 30 53



NOS. 563-564 No. OF LOCOS. 2  
 BUILT BY ALCO 1951  
 SPEC. No.

# DIESEL-ELECTRIC SWITCHING 8-WHEEL

ROAD CLASS 563  
 SYMBOL S-57  
 FUEL - DIESEL OIL

**POWER PLANT:**

1-1000 H.P. DIESEL-ELECTRIC UNIT  
 DIESEL ENGINE A.L. Co.  
 6 - 12 1/2" x 13" CYLS. VERT. TYPE, 4 CYCLE

**GENERATORS:**

1-G.E. DIRECT CURRENT TYPE GT-553-A  
 1-G.E. EXCITER TYPE G.M.G.-139-A2

**TRACTION MOTORS:**

4-G.E. DIRECT CURRENT TYPE G.E.731

GEAR RATIO-75:16

CONTROL EQUIP.

G.E. TYPE P.

MULTIPLE CONTROL  
 EQUIPPED.

**AIR COMPRESSOR:**

1-WESTINGHOUSE TYPE 3-CD  
 228 CU.FT./MIN. FULL SPEED, 76 CU.  
 FT./MIN. IDLING.

**BRAKE EQUIPMENT:**

WESTINGHOUSE EL-14 CLASP BRAKES  
 AUTOMATIC SHUTTERS

FUEL-DIESEL OIL 635 GALS.  
 LUBR. 80  
 ENGINE COOLING WATER 240  
 SAND 2700 LBS.

TRACTION POWER 57500 LBS.\*

MAX. PERMISSIBLE SPEED 60 M.P.H.

MAX. TRACK CURVE 50 FT. RAD.

WEIGHT IN WORKING ORDER:  
 TOTAL ON DRIVERS 231000 LBS.

TOTAL DRY(LIGHT) WT. 221600 "

AXLE LOAD 58360 "

REVISED:  
 12-30-53

RFE 186-51

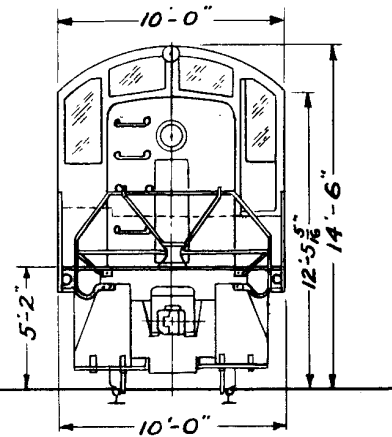
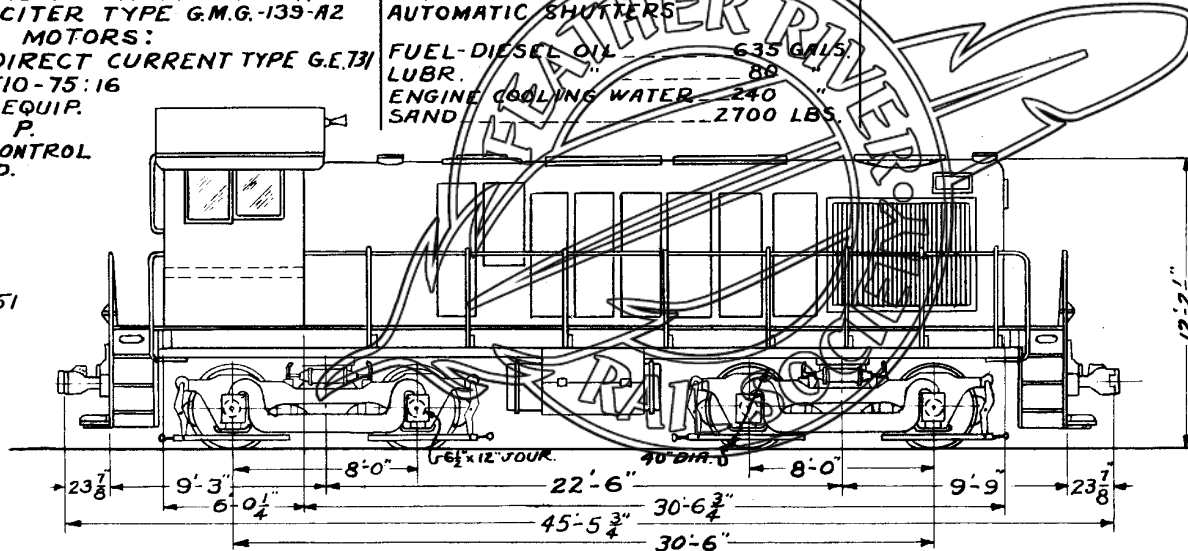

NOTE:  
 \* INCLUDES FULL LOAD FUEL  
 OIL, LUBR. OIL, WATER, SAND,  
 ALL EQUIP. AND 2-MEN.

R.D.C. 1-52

Nos. 581-585 No. of Locos. 5  
 BUILT-BALDWIN LOCO. WKS. 1945  
 SPEC. No. 44-DE-7  
 POWER PLANT

1-1000 H.P. DIESEL-ELECTRIC UNIT  
 DIESEL ENGINE, BALDWIN DELAVERGNE  
 MODEL YD.  
 8-12 $\frac{3}{4}$  x 15 $\frac{1}{2}$  CYL'S. VERT. TYPE, 4 CYCLE  
 GENERATORS  
 1-WESTINGHOUSE DIRECT-CURRENT  
 TYPE 480-B  
 1-WESTINGHOUSE EXCITER TYPE YG40-C  
 TRACTION MOTORS  
 4-WESTINGHOUSE DIRECT-CURRENT TYPE 362D  
 GEAR RATIO 68:14  
 CONTROL EQUIPMENT  
 WESTINGHOUSE ELECTRO-  
 PNEUMATIC.

AIR COMPRESSOR  
 1-GARDNER-DENVER TYPE WXO.  
 BRAKE EQUIPMENT  
 WESTINGHOUSE G-DS  
 CLASP BRAKES

FUEL-DIESEL OIL 700 GALS.  
 LUBR. 110 "  
 ENGINE COOLING WATER 290 "  
 SAND 3000 LBS.

TRACTION POWER 60000 LBS.  
 MAX. PERMISSIBLE SPEED 60 M.P.H.  
 MAX. TRACK CURVE 75 FT. RADIUS

ROAD CLASS 581  
 SYMBOL S-60  
 FUEL-DIESEL OIL  
 \* WEIGHT IN WORKING ORDER  
 TOTAL ON DRIVERS 245400 LBS.  
 TOTAL DRY (LIGHT) WEIGHT 232400 LBS.  
 AXLE LOAD 61350 LBS.

REVISED:  
 12-30-53

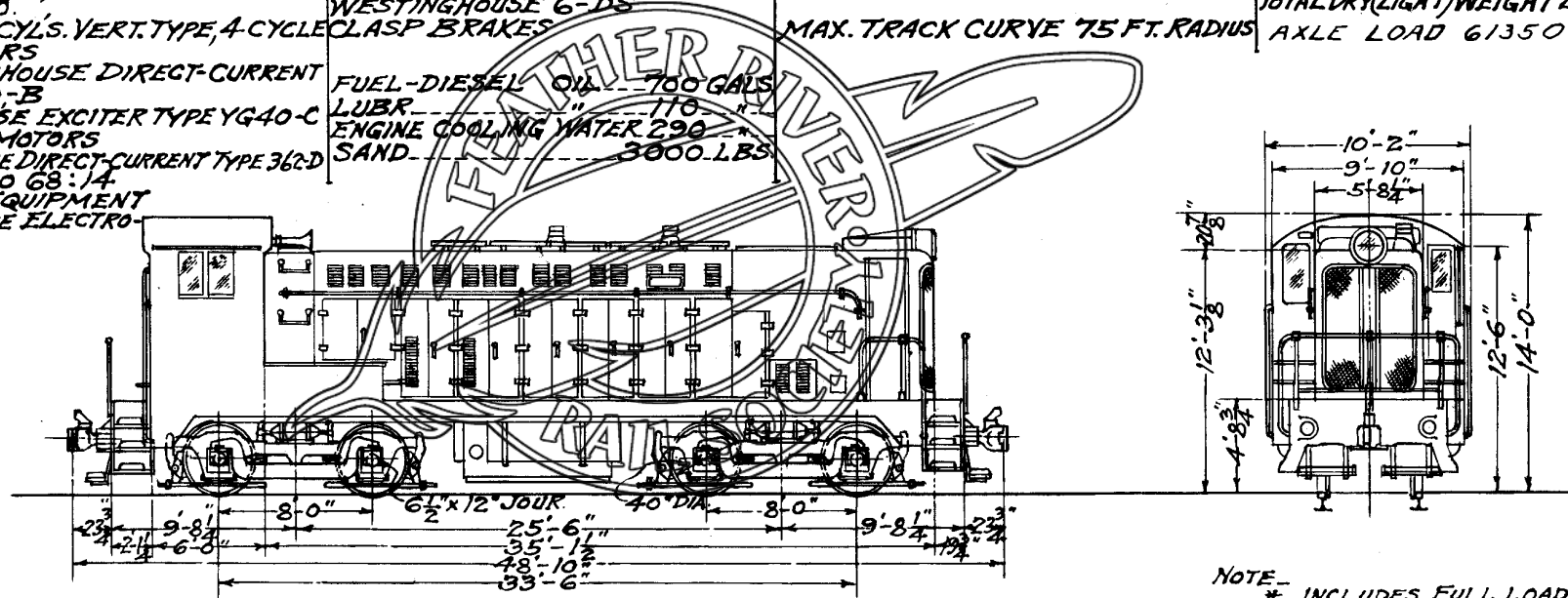

R.J.D. 2-4-46.

NOTE - INCLUDES FULL LOAD  
 FUEL OIL, LUBR. OIL, WATER, SAND,  
 ALL EQUIPT. AND 2-MEN.

NOS. 601-606. NO. OF LOCOS-6  
BUILT BY E.M.D. GEN. MOTORS 1952  
SPEC. No. 8023-A

# DIESEL-ELECTRIC SWITCHING 8-WHEEL

ROAD CLASS 601  
SYMBOL S-62  
FUEL DIESEL OIL

A.F.E. 209-51

**POWER PLANT:**  
1-1200 H.P. DIESEL-ELECTRIC UNIT  
DIESEL ENGINE BY G.M.C.  
12-8½" x 10" CYLS. V-TYPE, 2 CYCLE  
**GENERATORS:**  
1-E.M.D. 600 VOLT DIRECT CURRENT  
1-AUX. GEN.-VOLTAGE CONTROLLED  
BY LOAD REGULATOR  
**TRACTION MOTORS:**  
4-E.M.D. DIRECT CURRENT-SERIES WOUND  
**GEAR RATIO:** 72-15  
**CONTROL:**  
AUTO. FORWARD-MAN. REV.  
**OPERATION:**  
SINGLE OR MULTIPLE UNIT

**AIR COMPRESSOR:**  
1-GARDNER DENVER TYPE WXO  
CAPACITY-228 CFM FULL SPEED  
**BRAKE EQUIPMENT:**  
WESTINGHOUSE TYPE D-B  
CLASP BRAKES  
AUTOMATIC SHUTTERS

**TRACTIVE POWER** 62,000 LBS.\*  
**MAX. PERMISSIBLE SPEED** 65 MPH  
**MAX. TRACK CURVE** 100 FT. RAD.

**WEIGHT IN WORKING ORDER:**  
TOTAL ON DRIVERS 247,800 LBS.  
TOTAL DRY (LIGHT) WT. 237,700 "  
AXLE LOAD-----61,900 "

FUEL-DIESEL OIL-----600 GALS.  
ENGINE COOLING WATER-----223  
LUBRICATING OIL-----165  
SAND-----2800 LBS.

REVISED  
12-30-53

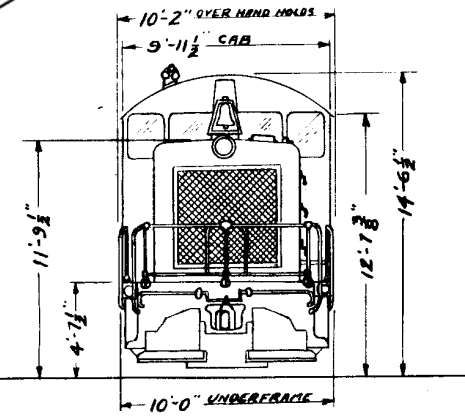
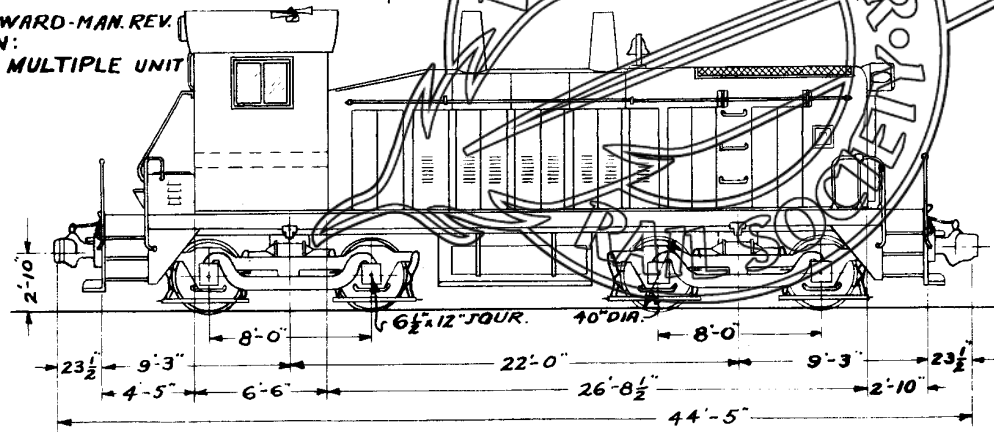

NOTE:  
\* INCLUDES FULL LOAD OF FUEL  
OIL, LUBR. OIL, WATER SAND  
AND ALL EQUIPMENT.

R.D.C. 1-52

Nos. 701-709 No. LOCOS.-9  
BUILT BY E.M.D. GEN. MOTORS-1952  
BUILDERS SPEC. No. 8018B

# DIESEL-ELECTRIC ROAD SWITCHING 8-WHEEL

ROAD CLASS 701  
SYMBOL RS-62  
FUEL - DIESEL OIL

\*WEIGHT IN WORKING ORDER:  
TOTAL ON DRIVERS - 251700 LBS.  
TOTAL DRY (LIGHT) WT. - 231500 "  
AXLE LOAD - 63450 "

### POWER PLANT:

1-1500 H.P. DIESEL-ELECTRIC UNIT  
DIESEL ENGINE BY G.M.C. 16-8 $\frac{1}{2}$ "x10" CYLS.,  
V-TYPE, 2-CYCLE

### GENERATORS:

1-EMD. 600 VOLT DIRECT CURRENT  
1-AUX. GEN. VOLTAGE CONTROLLED BY AUTO. REG.

### TRACTION MOTORS:

4-E.M.D. DIRECT CURRENT, SERIES WOUND, AXLE  
HUNG

GEAR RATIO: 62:15

### CONTROL:

AUTO. FORWARD & REVERSE, 2-STEP TRANSITION

### OPERATION:

SINGLE OR MULTIPLE UNIT  
DUAL CONTROLS

### AIR COMPRESSOR:

1-GARDNER-DENVER TYPE WXO,  
CAPACITY-225 CFM FULL SPEED

### BRAKE EQUIPMENT:

WESTINGHOUSE TYPE 24RL CLASP BRAKES  
DYNAMIC BRAKES

ELECTRIC IMMERSION HEATER-220 VOLTS  
WINTERIZATION

FUEL - DIESEL OIL 1600 GALS.  
LUBRICATING OIL 200  
ENGINE COOLING WATER 250  
SAND 18 CU. FT.

TRACTIVE POWER - 62100 LBS.

MAX. PERMISSIBLE SPEED - 65 M.P.H.

### MAX. TRACK CURVE:

SINGLE UNIT - 150' RAD. OR 39°

MULTIPLE UNIT OPER. - 274' " " 21°

WEIGHT WITH PLOW 253800 LBS.

REVISED:  
12-30-53

AFE 47-52

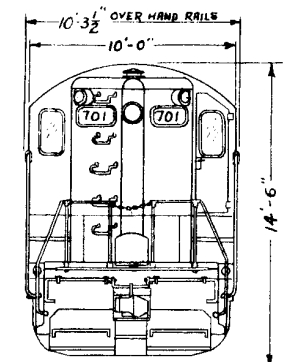
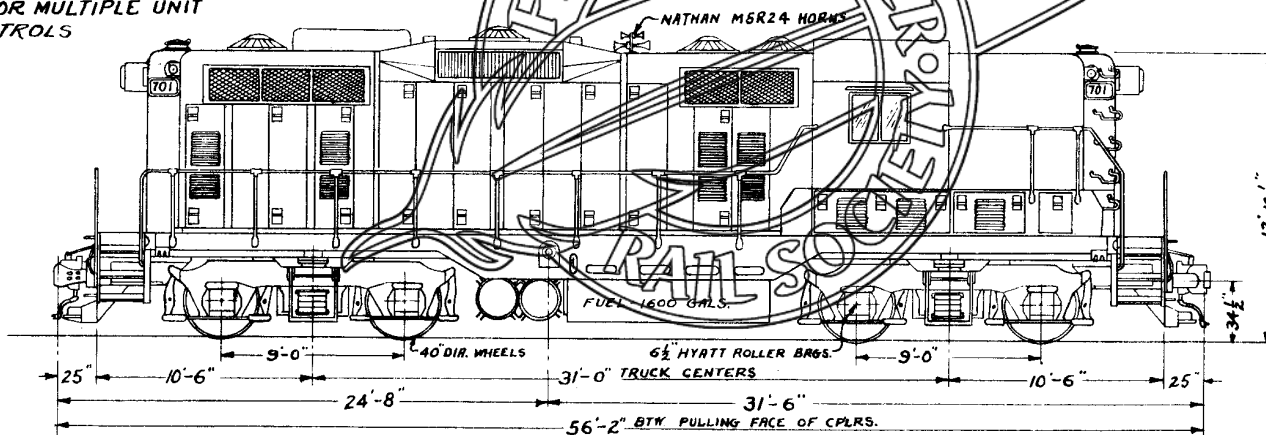

NOTE:  
\* INCLUDES FULL LOAD OF FUEL  
OIL, LUBE OIL, WATER, SAND AND  
ALL EQUIPMENT.

RDC 12-17-52

AFE 58-53

# DIESEL-ELECTRIC ROAD SWITCHING 8-WHEEL

ROAD CLASS 710  
SYMBOL RS-62  
FUEL - DIESEL OIL

Nos. 710-713 No. OF LOCOS.-4 EMD MODEL GP7  
BUILT BY E.M.D. GENERAL MOTORS CORP. 1953  
SPECIFICATION No. 8018-B

**POWER PLANT:**

1-1500 H.P. DIESEL-ELECTRIC UNIT  
DIESEL ENGINE BY GMC, 16-8 $\frac{1}{2}$ " x 10" CYLS.  
Y-TYPE, 2-CYCLE, MODEL No. 16-567B

**GENERATORS:**

1-EMD 600 VOLT DIRECT CURRENT  
1-AUX. GEN. VOLTAGE CONTROLLED BY AUTO. REG.

**TRACTION MOTORS:**

4-EMD DIRECT CURRENT, SERIES WOUND  
AXLE HUNG

GEAR RATIO: 62-15

**CONTROL:**

AUTO. FORWARD & REVERSE, 2-STEP TRANSITION  
DUAL CONTROLS

**OPERATION:**

SINGLE OR MULTIPLE UNIT

**AIR COMPRESSOR:**

1-GARDNER-DENVER TYPE WXO, CAPACITY-  
225 CFM @ 800 RPM

**BRAKE EQUIPMENT:**

WESTINGHOUSE TYPE 24RL CLASP BRAKES  
DYNAMIC BRAKES

**WINTERIZATION**

FUEL DIESEL OIL	1600 GALS.
LUBRICATING "	200 "
ENGINE COOLING WATER	230 "
SAND	18 CU. FT.

**\*WEIGHT IN WORKING ORDER:**

TOTAL ON DRIVERS --- 246,800 LBS.  
TOTAL DRY (LIGHT) WT. --- 230,000 "  
AXLE LOAD --- 61,700 "  
TRACTION POWER --- 61,700 "  
MAX. PERMISSIBLE SPEED - 65 MPH  
MAX. TRACK CURVE:

SINGLE UNIT OPER. 39° OR 150' RAD.  
MULTIPLE " " 21° " 274' "

**NOTE:**

\*INCLUDES FULL LOAD OF FUEL OIL, LUBE OIL, WATER, SAND AND ALL EQUIPMENT.



REVISED:  
12-30-53

RDC 6-24-53

FOR DIAGRAM SEE PAGE 9

AFE 158-55

# DIESEL-ELECTRIC ROAD SWITCHING 8-WHEEL

ROAD CLASS 725  
SYMBOL RS-62  
FUEL-DIESEL OIL

Nos. 725-732 No. OF LOCOS.-8 EMD MODEL GP9  
BUILT BY EMD GENERAL MOTORS CORP. 1955  
SPECIFICATION No. 8031

**POWER PLANT:**

1-1750 H.P. DIESEL-ELECTRIC UNIT  
DIESEL ENGINE BY GMC, 16-8 1/2 x 10" CYLS.  
V-TYPE, 2-CYCLE, MODEL No. 16-567C

**GENERATORS:**

1-EMD 600 VOLT DIRECT CURRENT  
1-AUX. GEN.-VOLTAGE CONTROLLED BY AUTO. REG.

**TRACTION MOTORS:**

4-EMD DIRECT CURRENT, SERIES WOUND,  
AXLE HUNG.

GEAR RATIO: 62-15

**CONTROL:**

AUTO. FORWARD & REVERSE, 4-STEP TRANSITION  
DUAL CONTROLS

**OPERATION:**

SINGLE OR MULTIPLE UNIT

**AIR COMPRESSOR:**

1-GARDNER-DENVER TYPE WXO,  
CAPACITY 225 CFM @ 800RPM.

**BRAKE EQUIPMENT:**

WESTINGHOUSE TYPE 24RL CLASP BRAKES  
DYNAMIC BRAKES

**WINTERIZATION**

FUEL-DIESEL OIL	21600 GALS.
LUBRICATING OIL	200 "
ENGINE COOLING WATER	227 "
SAND	18 CU. FT.

**\*WEIGHT IN WORKING ORDER:**

TOTAL ON DRIVERS	247,600 LBS.
TOTAL DRY (LIGHT) WT.	230,700 "
AXLE LOAD	61,900 "
TRACTION POWER	61,900 "
MAX. PERMISSIBLE SPEED	65 MPH
MAX. TRACK CURVE:	

SINGLE UNIT OPER.	39° OR 150' RAD.
MULTIPLE " "	21° OR 274' "

**NOTE:**

\*INCLUDES FULL LOAD OF FUEL OIL, LUBE OIL, WATER, SAND AND ALL EQUIPMENT.

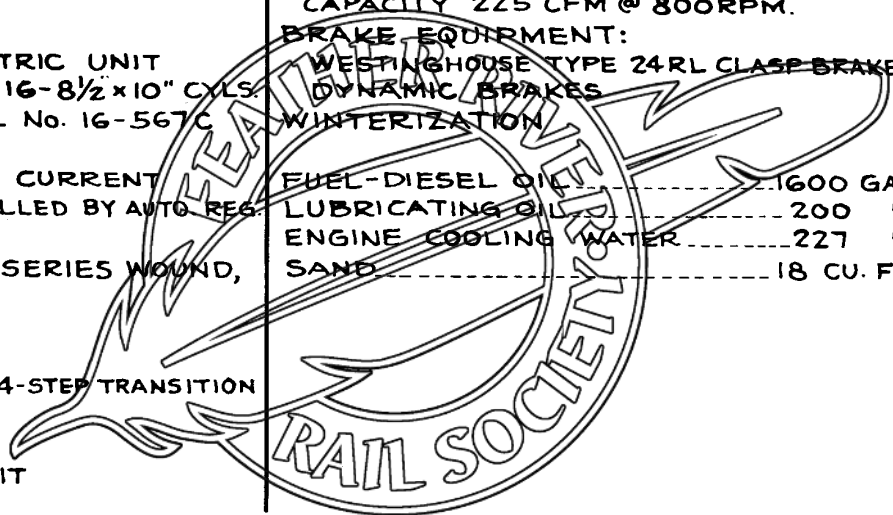

# DIESEL-ELECTRIC PASSENGER 24 WHEEL

COMPRESSORS  
DENVER TYPE WXE  
EQUIPMENT  
TYPE 24 RL  
EQUIPMENTS

FUEL DIESEL OIL	4500 GALS
LUBE	600 "
ENGINE COOLING WATER	660 "
BOILER	3000 "
TOILET	50 "
SAND	4800 LBS

TRACTIVE POWER TOTAL 176,000 LBS.  
MAX. PERMISSIBLE SPEED 95 M.P.H.  
MAX. TRACK CURVE 21°  
MIN. CONTINUOUS RATING SPEED 22.5 M.P.H.

ROAD CLASS 801  
SYMBOL D-176  
FUEL - DIESEL OIL

\* WEIGHTS IN WORKING ORDER  
TOTAL ON DRIVERS 733,600 LBS.

TOTAL DRY (LIGHT) WEIGHT 666,000 LBS.  
AXLE LOAD 61100 LBS.

\*\* WITH INCREASED FUEL CAPY. (AFE 7-54)

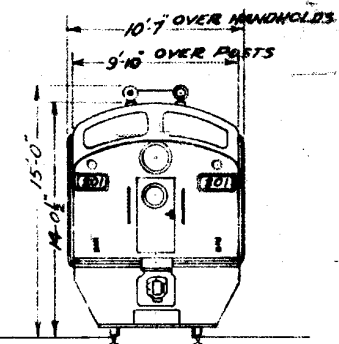
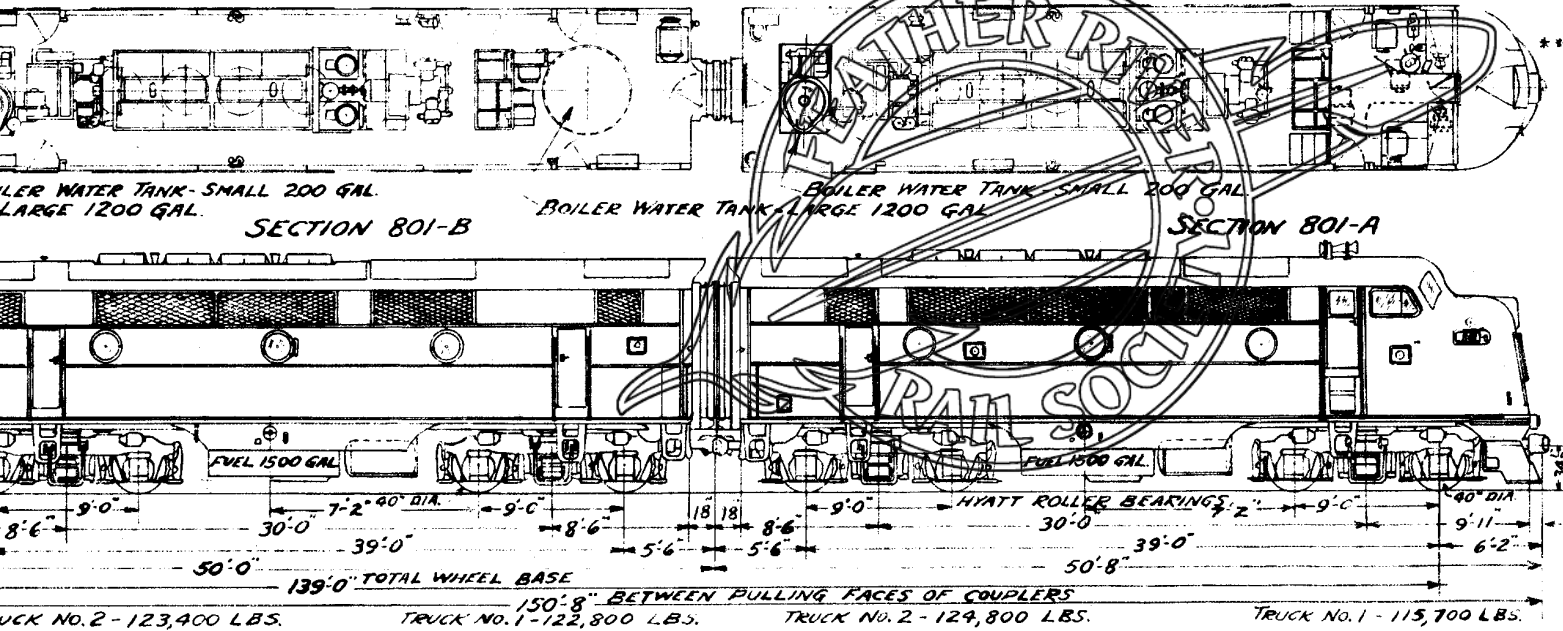

NOTE:  
\* INCLUDES FULL LOAD OF FUEL OIL,  
LUBE OIL, WATER, SAND, ALL EQUIPT

TRUCK NO. 2 - 123,400 LBS. TRUCK NO. 1 - 122,800 LBS. TRUCK NO. 2 - 124,800 LBS. TRUCK NO. 1 - 115,700 LBS.

NOS. 801-803 NO. OF LOCOS 3  
 BUILT BY ELECTRO-MOTIVE CORP. 1947  
 SPEC NO. E.M.C. NOS 8002-8003

POWER PLANT

3-1500 H.P. DIESEL ELECTRIC UNITS  
 DIESEL ENGINES 16-8 1/2" X 10" CYLS. V TYPE, 2 CYCLE  
 3-E.M.C. MODEL 16-567B  
 SERIAL NOS. E.M. 3925-3933 INCL.  
 STEAM GENERATORS  
 3-VAPOR CLARKSON-1600 LBS. P.H.

MAIN GENERATORS  
 3-E.M.C. TYPE D-8 NOM. VOLTAGE 600  
 TRACTION MOTORS  
 12-E.M.C. TYPE D17B VOLTAGE 600  
 GEAR RATIO 57:20  
 CONTROL EQUIPMENT  
 E.M.C. VOLTAGE 64-74

4500 H.P. DIESEL-ELECTRIC

AIR COMPRESSORS  
 3-GARDNER-DENVER TYPE WXE  
 BRAKE EQUIPMENT  
 WESTINGHOUSE 24 RL  
 CLASP BRAKES

FUEL DIESEL  
 LUBE OIL  
 ENGINE COOLING  
 BOILER  
 TOILET  
 SAND

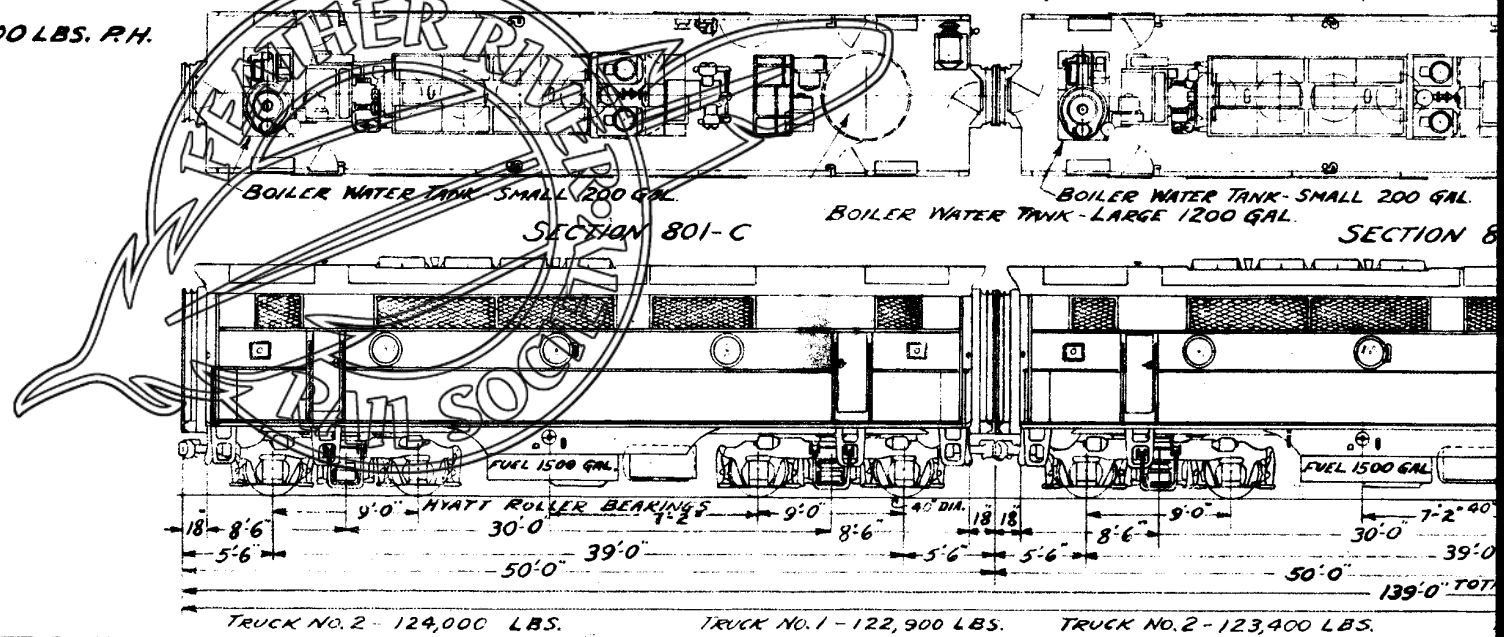

RWL 7-13-47  
 REV. 1-20-49  
 12-30-52  
 7-12-52

TRUCK NO. 2 - 124,000 LBS.

TRUCK NO. 1 - 122,900 LBS.

TRUCK NO. 2 - 123,400 LBS.



Nos. 804-805, No. OF LOCOS. 2  
 BUILT BY ELECTRO-MOTIVE DIVN. G.M.C. 1950  
 SPEC. No. EMD 8015 AND 8014 WITH SUPPL. No. 1.  
 MODEL FP-7, LEAD & F-7 BOOSTER UNITS, SER. Nos. 9002-9007

**POWER PLANT:**

3-1500 H.P. DIESEL ELECTRIC UNITS  
 DIESEL ENGINE BY G.M.C., 16-8 $\frac{1}{2}$  x 10" CYLS.  
 V-TYPE, 2 CYCLE, MODEL No. 16-567B

**MAIN GENERATORS:**

3-EMD TYPE D-14, NOM. VOLTAGE -600

**TRACTION MOTORS:**

12-EMD TYPE D-27B, 600 VOLTS DC, SERIES WOUND  
 GEAR RATIO: 57-20

**CONTROL:**

EMD ELECTRIC CONTROL-FULLY AUTOMATIC  
 FORWARD AND REVERSE TRANSITION  
 HOSTLER'S CONTROL STATION IN ALL "B" UNITS

**AIR COMPRESSORS:**

3-GARDNER-DENVER, TYPE WXE G-D, CAPACITY -  
 180 C.F.M. @ 800 RPM

**STEAM GENERATORS:**

3-VAPOR-CLARKSON 2500 L.P.H. TYPE OK 4625-14 DNRS

**BRAKE EQUIPMENT:**

WESTINGHOUSE CLASP BRAKES, TYPE 2RL  
 DYNAMIC BRAKES

FUEL DIESEL OIL	4500	GALS.
LUBE OIL	600	"
ENGINE COOLING WATER	675	"
BOILER WATER	3900	"
TOILET WATER	50	"
SAND	48 CU.FT. - 4800	LBS.

TRACTION POWER - TOTAL	176,000	LBS.
MAX. PERMISSIBLE SPEED	35	MPH
MAX. TRACK CURVE	23° OR 250'	RAD.
MIN. CONTINUOUS RATING SPEED	22	MPH

RDC-JRL 7-21-53

# 4500 H.P. DIESEL-ELE

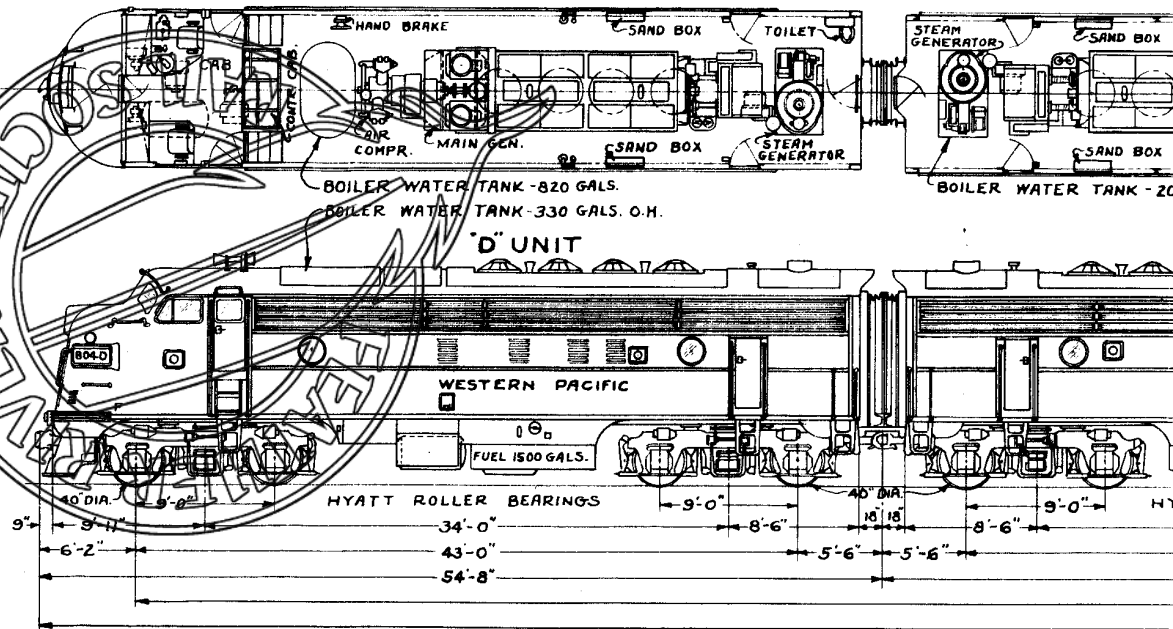

TRUCK No. 6 - 122,060 LBS.

TRUCK No. 5 - 130,620 LBS. TRUCK No. 4 - 122,670 LBS.

REVISED:  
7-12-54

# ELECTRIC PASSENGER - 24 WHEEL

ROAD CLASS 804  
 SYMBOL D-176  
 FUEL - DIESEL OIL

**\* WEIGHTS IN WORKING ORDER:**  
 TOTAL ON DRIVERS ..... 753,500 LBS.  
 TOTAL DRY (LIGHT) WT. .... 688,600 LBS.  
 AXLE LOAD ..... 62,800 LBS.

\*\*\* WITH INCREASED FUEL CAPY. (AFE 7-54)

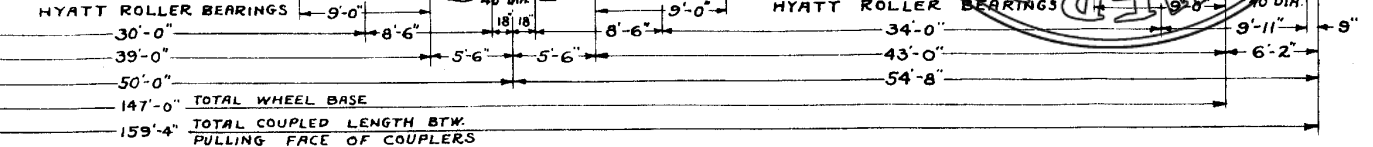
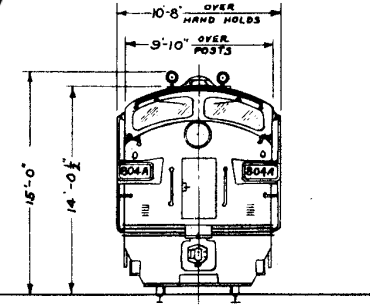
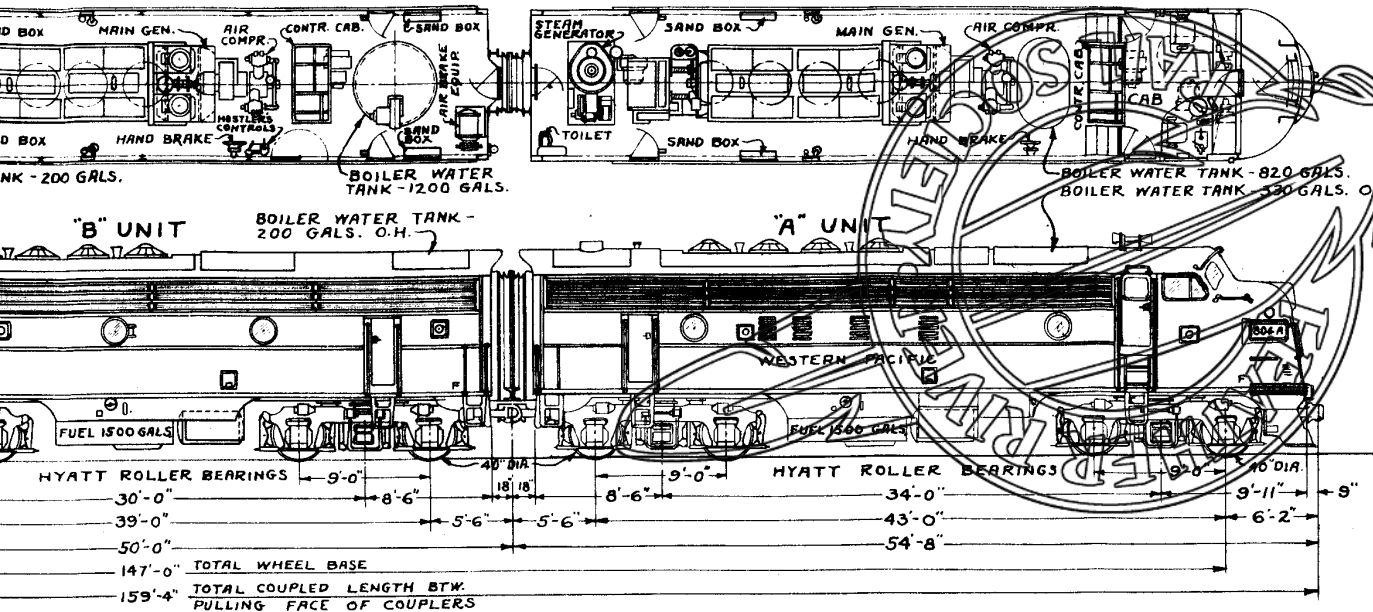

**NOTE:**  
 \* INCLUDES FULL LOAD OF FUEL OIL, LUBE OIL, WATER, SAND AND ALL EQUIPMENT.

670 LBS. TRUCK No. 3 - 125,350 LBS. TRUCK No. 2 - 130,650 LBS.

TRUCK No. 1 - 122,150 LBS.

Nos. 901-903 No. of Locos. 3.  
 BUILT BY ELECTRO-MOTIVE CORP. 1941  
 SPEC. NO. E.M.C. NO. 606-B, WITH SUPPL. NO. 1  
 POWER PLANT  
 4-1350 H.P. DIESEL-ELECTRIC UNITS  
 DIESEL ENGINES. 16-8 $\frac{1}{2}$ x10" CYLS. V TYPE, 2 CYCLE  
 4-E.M.C. MODEL 16-567  
 SERIAL NOS. EM. 1410-1421 INCL.

MAIN GENERATORS  
 4-E.M.C. TYPE D-8 NOM. VOLTAGE 600  
 TRACTION MOTORS  
 16-E.M.C. TYPE DTK VOLTAGE 600  
 GEAR RATIO 62:15  
 CONTROL EQUIPMENT  
 E.M.C. VOLTAGE 64-76

# 5400 H.P. DIESEL-ELECTRIC

AIR COMPRESSORS  
 4-GARDNER-DENVER TYPE W X E  
 BRAKE EQUIPMENT  
 WESTINGHOUSE 8 EL  
 CLASP BRAKES  
 DYNAMIC " (AFE 201-51)

NOTE - THIS BOILER NOT USED ON LOCOS. 901-903

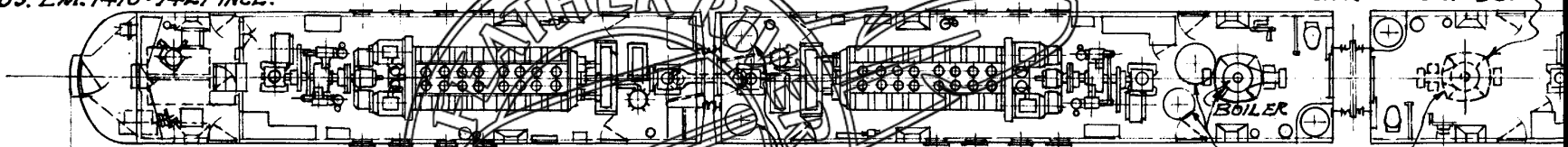

SECTION 901 D

SECTION 901 C

STEAM GEN. & BOILER WATER SUPPLY TANKS REMOVED - 901-903 AFE C-13-50; 904-912 AFE C-56-51-

STEAM GEN. REMOVED - 904-912 ON AFE

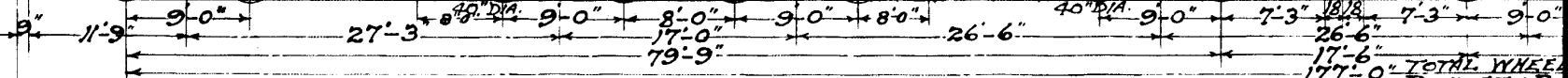
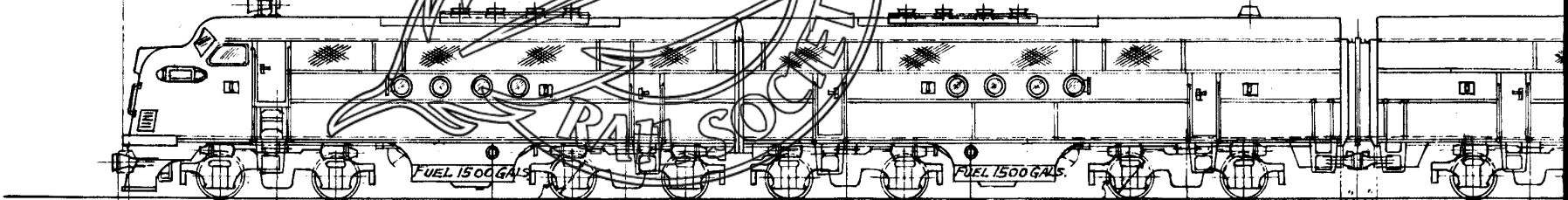

R.J.D. 4-42. TRUCK No. 1 113880 LBS. TRUCK No. 2 116300 LBS. TRUCK No. 3 114160 LBS. TRUCK No. 4 114170 LBS. TRUCK 10987

6-17-52  
 12-30-53

# ELECTRIC FREIGHT 32-WHEEL

W X E

FUEL DIESEL OIL	6000 GALS.
LUBE	600 "
ENGINE COOLING WATER	980 "
BOILER	200 "
TOILET	50 "
SAND	8000 LBS.

TRACTIVE POWER TOTAL 225000 LBS.

MAX. PERMISSIBLE SPEED 65 M.P.H.

MAX. TRACK CURVE 23°

BOILER NOT USED  
S. 901-903

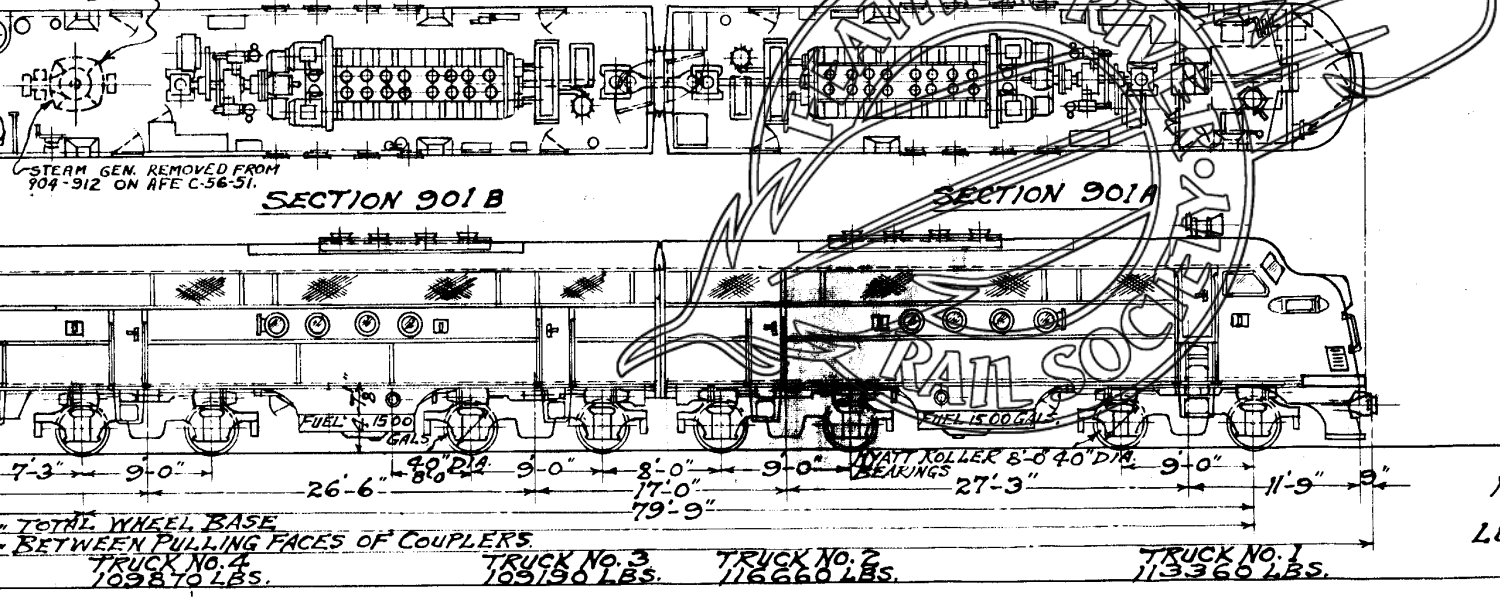

ROAD CLASS 901  
SYMBOL D-225  
FUEL-DIESEL OIL  
\* WEIGHTS IN WORKING ORDER  
TOTAL ON DRIVERS 907590 LBS

TOTAL DRY (LIGHT) WEIGHT 845990 LBS  
AXLE LOAD 56800 LBS.

\*\* WITH INCREASED FUEL CAPY (NFE 197-5)

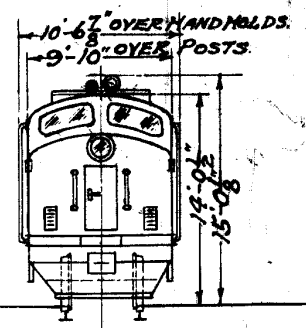

NOTE -  
\* INCLUDES FULL LOAD OF FUEL, OIL, LUBE OIL, WATER, SAND, ALL EQUIPT.

# 5400 H.P. DIESEL-ELECTRIC FREIGHT 32-WHEEL

ROAD CLASS 904  
SYMBOL D-225

NOS. 904-906 NO. OF LOCOS. 3  
BUILT BY ELECTRO-MOTIVE CORP. 1943  
SPEC. NO. E.M.C. NO. 606-D WITH SUPPL. NO. 1  
POWER PLANT  
4-1350 H.P. DIESEL-ELECTRIC UNITS  
DIESEL ENGINES 16-8 $\frac{1}{2}$  x 10 CYLS. V TYPE, 2 CYCLE  
4-E.M.C. MODEL 16-567-A  
SERIAL NOS. E.M.C. 2096-2107 INCL.

MAIN GENERATORS  
4-E.M.C. TYPE D-8 NOM. VOLTAGE 600  
TRACTION MOTORS  
16-E.M.C. TYPE D7K-1 VOLTAGE 600  
GEAR RATIO 62:15  
CONTROL EQUIPMENT  
E.M.C. VOLTAGE 6476

AIR COMPRESSORS  
4-GARDNER-DENVER TYPE WXE  
BRAKE EQUIPMENT  
WESTINGHOUSE 8 EL  
CLASP BRAKES  
DYNAMIC BRAKES

FUEL - DIESEL OIL	6000 GALS
LUBRICATING OIL	760 "
ENGINE COOLING WATER	980 "
BOILER	400 "
TOILET	50 "
SAND	8000 LBS.

FUEL DIESEL OIL  
\*\* WEIGHT IN WORKING ORDER  
TOTAL ON DRIVERS 915920 LBS  
AXLE LOAD 57300 LBS.  
TOTAL DRY (LIGHT) WEIGHT 853820 LBS.  
WEIGHT WITH PLOW 938000 LBS.

TRACTION POWER TOTAL 225000 LBS.  
MAX. PERMISSIBLE SPEED 65 M.P.H.

MAX. TRACK CURVE 23°

\* WITH INCREASED FUEL CAPY.  
REF. 197-51

NOTE:  
\*\* INCLUDES FULL LOAD OF FUEL  
OIL, LUBR. OIL, WATER, SAND  
AND ALL EQUIPMENT.

## LOADED WEIGHTS

SECTION-905 D		SECTION-905 C		SECTION-905 B		SECTION-905 A		TOTAL WT.
TRUCK No. 1	TRUCK No. 2	TRUCK No. 3	TRUCK No. 4	TRUCK No. 4	TRUCK No. 3	TRUCK No. 2	TRUCK No. 1	
116800 LBS	116010 LBS	108790 LBS	116760 LBS	116880 LBS	108270 LBS	115770 LBS	116640 LBS	915920 LBS

FOR DIAGRAM USE PAGE-13

# 5400 H.P. DIESEL-ELECTRIC FREIGHT 32-WHEEL

ROAD CLASS 907  
 SYMBOL D-225  
 FUEL DIESEL OIL.

No's. 907-912 No. of Loco's. 6  
 BUILT BY ELECTRO-MOTIVE CORP. 1944  
 SPEC. No. E.M.C. No. 606-D WITH SUPPL. No. 1

**POWER PLANT**  
 4-1350 H.P. DIESEL-ELECTRIC UNITS  
 DIESEL ENGINES 16-8 1/2" X 10" CYLS. V TYPE, 2 CYCLE  
 4-E.M.C. MODEL 16-567-A  
 SERIAL No's. E.M.C. 2783-2806 INCL.

**AIR COMPRESSORS**  
 4-GARDNER-DENYER TYPE WXE  
**BRAKE EQUIPMENT**  
 WESTINGHOUSE 8 EL  
**CLASP BRAKES**  
 DYNAMIC BRAKES

**MAIN GENERATORS**  
 4-E.M.C. TYPE D-8 NOM. VOLTAGE 600  
**TRACTION MOTORS**  
 16-E.M.C. TYPE D7K-1 VOLTAGE 600  
 GEAR RATIO 62.15  
**CONTROL EQUIPMENT**  
 E.M.C. VOLTAGE 64-76

FUEL - DIESEL OIL - 6000 GALS.  
 LUBRICATING " 760 "  
 ENGINE COOLING WATER 980 "  
 BOILER 400 "  
 TOILET 50 "  
 SAND 8000 LBS.

\*\*  
**WEIGHT IN WORKING ORDER**  
 TOTAL ON DRIVERS 926620 LBS  
 AXLE LOAD 59000 LBS.  
 TOTAL DRY (LIGHT) WEIGHT 864520 LBS.  
 WEIGHT WITH PLOW 943000 LBS.  
**TRACTION POWER TOTAL 225000 LBS**  
**MAX. PERMISSIBLE SPEED 65 M.P.H.**

MAX. TRACK CURVE 23°

\* WITH INCREASED FUEL CAPY.  
 RFE 197-51

NOTE:  
 \*\* INCLUDES FULL LOAD OF FUEL  
 OIL, LUBR. OIL, WATER, SAND,  
 AND ALL EQUIPMENT.

## LOADED WEIGHTS

SECTION- 910D		SECTION- 910C		SECTION- 910B		SECTION- 910A		TOTAL WT.
TRUCK No1	TRUCK No2	TRUCK No3	TRUCK No4	TRUCK No4	TRUCK No3	TRUCK No2	TRUCK No1	
117470 LBS	116730 LBS	11640 LBS	117560 LBS	116800 LBS	113280 LBS	115310 LBS	117830 LBS	926620 LBS

FOR DIAGRAM USE PAGE-13

**NOS. 913-921, NO. OF LOCOS. 9**

BUILT BY ELECTRO-MOTIVE DIV'N. - G.M.C. 1950.  
 SPEC. NO. E.M.D. 8013 & 8014 - SUPPL. NO. 1.  
 MODEL F7, SERIAL NOS. 8962 TO 8997 INCL.  
 POWER PLANT: 4-1500 H.P. DIESEL-ELECTRIC UNITS.  
 DIESEL ENGINES: 16-8½"x10" CYLS., V TYPE,  
 2 CYCLE; 4-E.M.D. MODEL 16-567 B.

**6000 H.P. DIESEL-ELECTRIC**

MAIN GENERATORS: 4 E.M.D. TYPE D12-15, NOM. VOLTAGE 600.  
 TRACTION MOTORS: 16 E.M.D. TYPE D-27, VOLTAGE 600.  
 GEAR RATIO 62:15  
 CONTROL EQUIP'T., E.M.D. ELECTRIC-CONTROL CIRCUIT VOLTAGE 64-74  
 AIR COMPRESSORS: 4 GARDNER-DENVER 2 STAGE, TYPE WXE.

STEAM GENERATOR:  
 ONE VAPOR-CLARKSON 40"  
 TYPE OK-4740-74-DO-  
 BRAKE EQUIPMENT:  
 W.A.B./N.Y.A.B. 24RL-CLASS

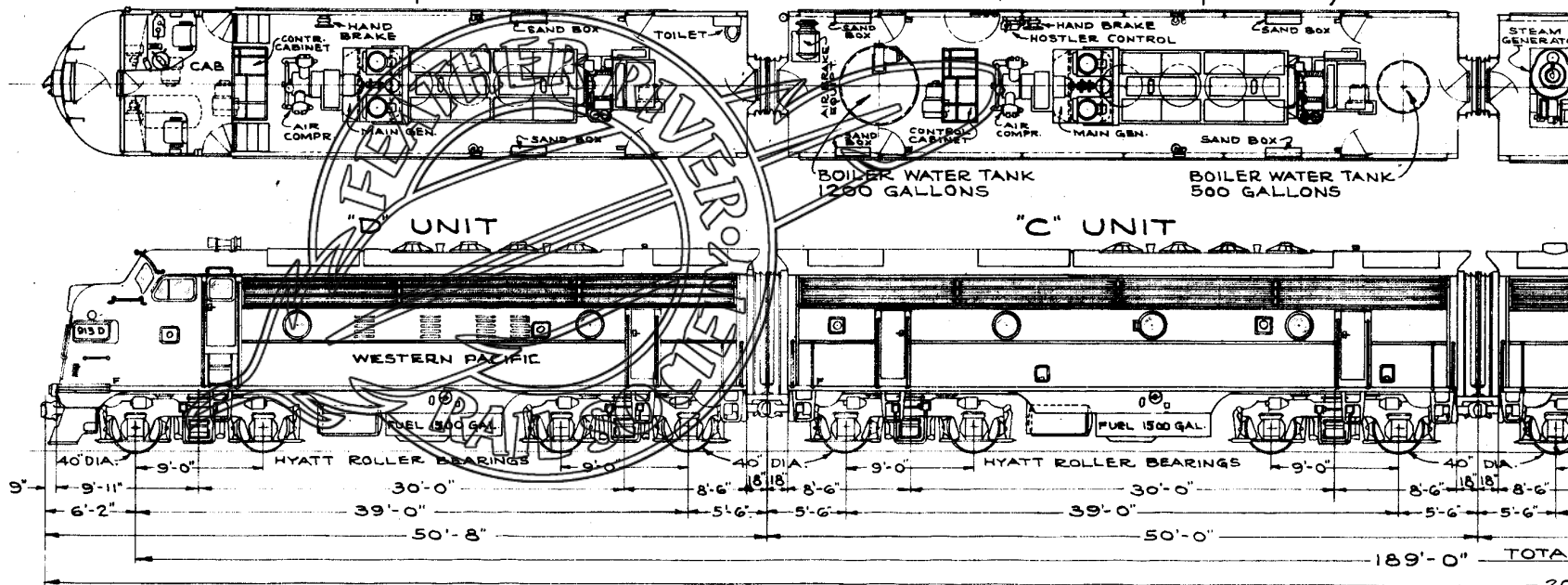

REV.  
 7-16-53  
 12-30-53

J.R.L. 4-12-51. TRUCK NO. 8-117, 920 LBS. TRUCK NO. 7-119, 830 LBS. TRUCK NO. 6-122, 920 LBS. TRUCK NO. 5-124, 850 LBS. TRUCK

# ELECTRIC FREIGHT - 32 WHEEL

GENERATOR:  
VAPOR-CLARKSON 4000 LBS. P.H.  
OK-4740-74-DO-F.  
EQUIPMENT:  
N.Y.A.B. 24RL-CLASP BRAKES:

FUEL DIESEL OIL	6000	GALS.
LUBE OIL	3000	GALS.
ENGINE COOLING WATER	3000	GALS.
BOILER WATER	3000	GALS.
TOILET WATER	500	GALS.
SAND (64 CU. FT.)	6400	LBS.

TRACTION POWER - TOTAL 239,000 LBS.  
MAX. PERMISSIBLE SPEED 65 M.P.H.  
MAX. TRACK CURVE 23°  
MIN. CONTINUOUS RATING SPEED 11 M.P.H.

**ROAD CLASS 913**  
**SYMBOL D-239**  
**FUEL - DIESEL OIL**

\*WEIGHTS IN WORKING ORDER  
TOTAL ON DRIVERS 979,400 LBS.  
TOTAL DRY (LIGHT) WEIGHT 886,500 LBS.  
AXLE LOAD = 64,560 LBS.

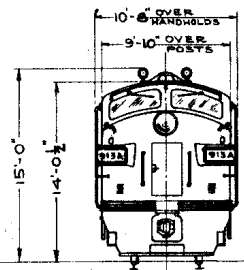
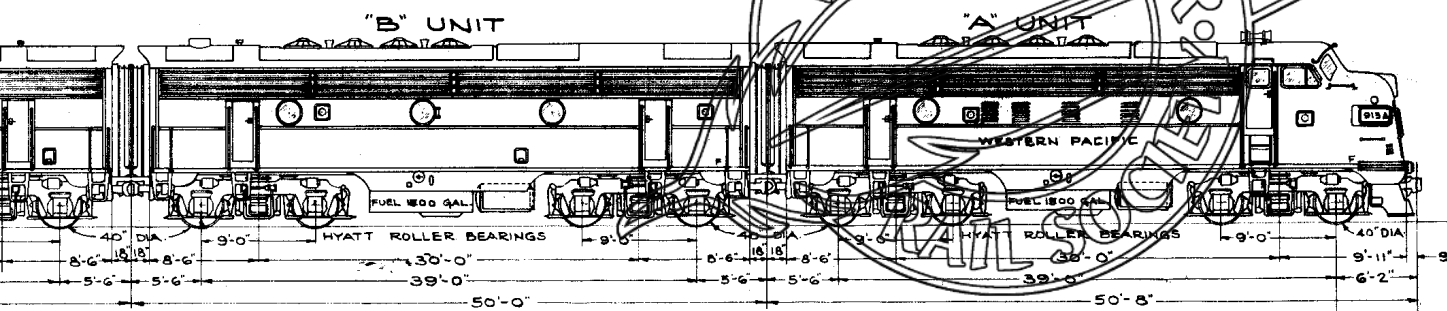
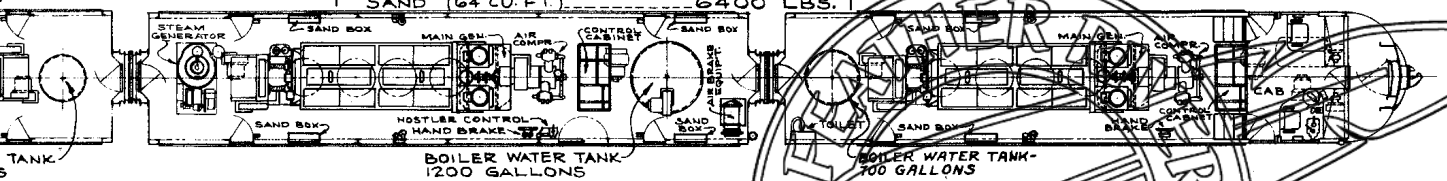

**NOTE:**  
\*INCLUDES FULL LOAD OF FUEL OIL, LUBE OIL, WATER, SAND AND ALL EQUIPMENT.

24,850 LBS. TRUCK NO. 4 - 126,000 LBS. TRUCK NO. 3 - 123,170 LBS. TRUCK NO. 2 - 129,120 LBS. TRUCK NO. 1 - 115,590 LBS.



AFE 186-51

# 6000 H.P. DIESEL-ELECTRIC FREIGHT 32-WHEEL

ROAD CLASS 922  
SYMBOL D-2  
FUEL-DIESEL OIL

Nos. 922-924 No. OF LOCOS.-3 E.M.D. MODEL F-7  
BUILT BY E.M.D. GENERAL MOTORS CORP. 1951  
SPECIFICATION No. 8013 & 8014 -SUPPL. Nos. 1 & 2

**POWER PLANT:**

4-1500 H.P. DIESEL ELECTRIC UNITS  
DIESEL ENGINE BY GMC., 16-8 1/2" x 10" CYLS.  
V-TYPE, 2-CYCLE, MODEL 16-567B

**GENERATORS:**

4-EMD 600 VOLT DIRECT CURRENT - MAIN GEN.  
4-AUX. CONSTANT VOLTAGE - CONTROLLED BY AUTO. REG.  
4-ALTERNATORS - EMD A.C. 149 V., 3-PHASE 6-POLE

**TRACTION MOTORS:**

16-E.M.D. TYPE D-27, 600 VOLTS D.C. SERIES  
WOUND, AXLE HUNG

GEAR RATIO: 62-15

**CONTROL:**

MANUAL OR AUTO. FORWARD & REVERSE

**AIR COMPRESSOR:**

4-GARDNER-DENVER, 2-STAGE, TYPE WXE  
180 CFM @ 800 RPM

**BRAKE EQUIPMENT:**

WESTINGHOUSE TYPE 24RL CLASP BRAKES  
DYNAMIC BRAKES

**STEAM GENERATOR:**

1-VAPOR-CLARKSON 4000 LB. TYPE OK-4740

FUEL-DIESEL OIL

6000 GAL.

LUBRICATING "

800 "

ENGINE COOLING WATER

890 "

BOILER WATER

3600 "

TOILET WATER

50 "

SAND

(64 CU.FT.) 6400 LBS.

**\*WEIGHT IN WORKING ORDER:**

TOTAL ON DRIVERS 951,800 LBS.  
TOTAL DRY (LIGHT) WT. 885,000 "  
AXLE LOAD 61,245 "  
TRACTIVE POWER, TOTAL 238,000 "  
MAX. PERMISSIBLE SPEED 65 MPH.  
MIN. CONT. RATING " 11 "  
MAX. TRACK CURVE 23° OR 250' RAD.

**NOTE:**

\* INCLUDES FULL LOAD OF FUEL OIL,  
LUBE OIL, WATER, SAND & ALL EQUIP.

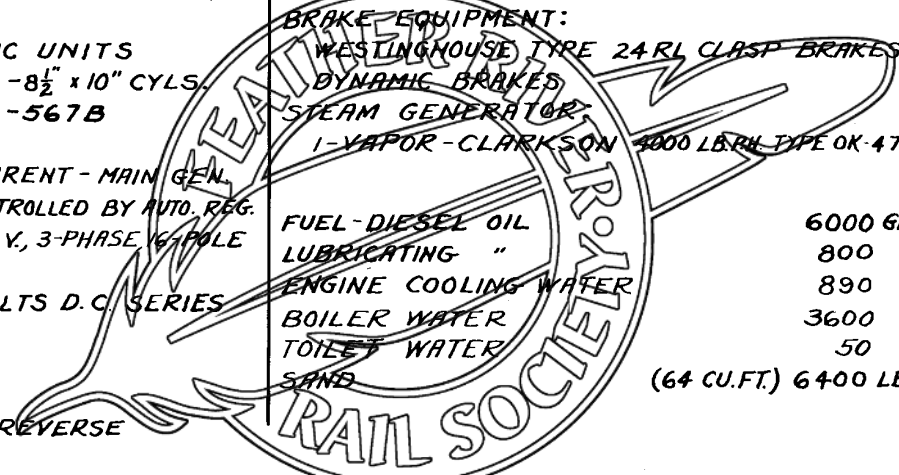

**LOADED WEIGHTS**

SECTION D		SECTION C		SECTION B		SECTION A		TOTAL WEIGHT
TRUCK No. 1	TRUCK No. 2	TRUCK No. 3	TRUCK No. 4	TRUCK No. 4	TRUCK No. 3	TRUCK No. 2	TRUCK No. 1	
115,220 LBS.	116,680 LBS.	122,250 LBS.	121,830 LBS.	121,940 LBS.	122,490 LBS.	116,460 LBS.	114,930 LBS.	951,800 LBS.

FOR DIAGRAM SEE PAGE No. 16

REVISED  
12-30-53

REV. 3-27-52

TS.R.R. No. 735 No. of ENGS. 1  
 BUILT - GEN. ELEC. CO. 1946  
 SPEC. NO. RY-24147-G  
 POWER PLANT  
 2-190 H.P. CATERPILLAR DIESEL  
 ENGINES TYPE D-17000  
 8-5 3/4" x 8" CYLS. V TYPE, 4 CYCLE  
 GENERATORS  
 2-G.E. DIRECT CURRENT TYPE GT-555  
 2-G.E. EXCITER TYPE G.M.G.-140  
 TRACTION MOTORS  
 4 G.E. DIRECT CURRENT TYPE G.E.-733  
 GEAR RATIO 11.25 TO 1  
 CONTROL EQUIP.  
 G.E. TYPE M.

# DIESEL-ELECTRIC SWITCHING 8-WHEEL

ROAD CLASS TS735  
 SYMBOL S-26  
 FUEL-DIESEL OIL  
 \* WEIGHTS IN WORKING ORDER  
 TOTAL ON DRIVERS 88000 LBS.  
 TOTAL DRY (LIGHT) WT. 84,900 LBS.  
 AXLE LOAD 22000 LBS.

AIR COMPRESSOR  
 2 GARDNER-DENVER TYPE ADS.  
 BRAKE EQUIPMENT  
 WESTINGHOUSE A.B.CO. STRAIGHT  
 AND AUTOMATIC SCHEDULE 74-LL  
 FUEL-DIESEL OIL 250 GAL.  
 LUBR. 250 GAL.  
 ENGINE COOLING WATER 40 GAL.  
 SAND 800 LBS.

TRACTIVE POWER 26400 LBS.  
 MAX. PERMISSIBLE SPEED 35 M.P.H.  
 MAX. TRACK CURVE 50 FT. RADIUS.

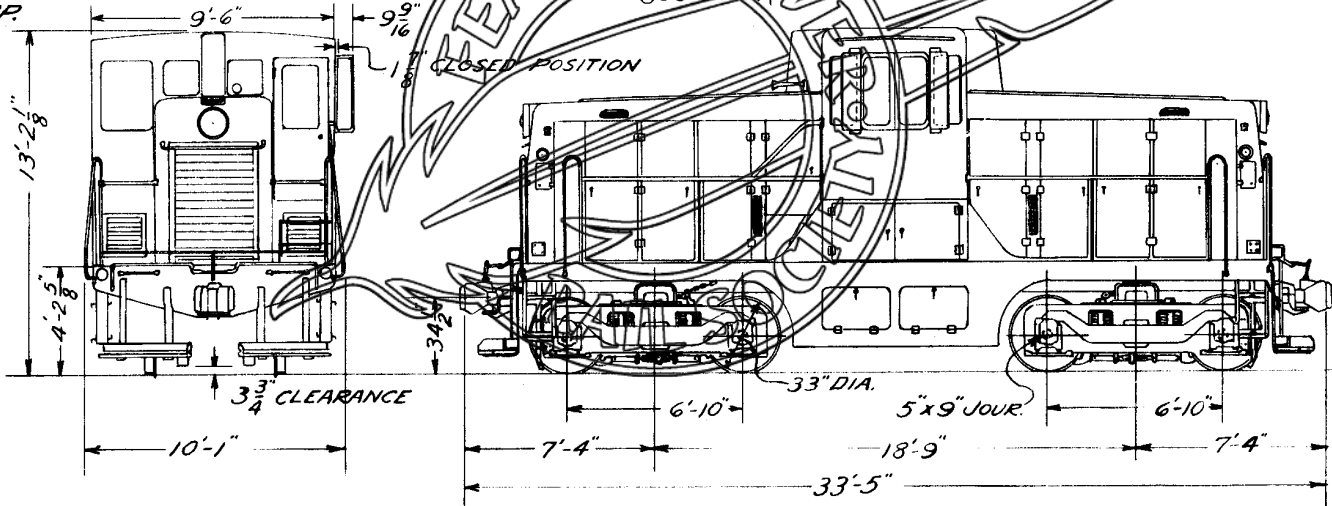

NOTE -  
 \* INCLUDES FULL LOAD  
 FUEL OIL, LUBR. OIL, WATER,  
 SAND, ALL EQUIP & 2 MEN.

R.W.C. 3-15-47

T.S.R.R. Nos 741-743 N<sup>o</sup> OF LOCO'S 3  
BUILT-GEN. ELEC. CO. 1948(743-1953)  
SPEC. No. RY-24224

**POWER PLANT**

1-600 H.P. COOPER-BESSEMER  
DIESEL ENGINE TYPE FWL-6T  
6-9" X 10½" CYLS, IN LINE TYPE, 4 CYCLE

**GENERATORS**

1-G.E. DIRECT CURRENT TYPE GT-571  
1-G.E. EXCITER TYPE G.M.G.-146

**TRACTION MOTORS**

4 G.E. DIRECT CURRENT TYPE G.E. 748

GEAR RATIO 105:15  
CONTROL EQUIPMENT  
G.E. TYPE M

AIR COMPRESSOR  
1 WESTINGHOUSE MODEL 4ZB  
BRAKE EQUIPMENT  
NEW YORK A.B. CO. STRAIGHT  
& AUTOMATIC SCHEDULE 74 EL

FUEL - DIESEL OIL - 500 GALS.  
LUBR. - 125 GALS.  
ENG. COOLING WATER - 100 GALS.  
SAND - 1250 LBS.

TRACTION POWER 4,300 LBS.  
MAX. PERMISSIBLE SPEED 55 M.P.H.  
MAX. TRACK CURVE 75 FT. RADIUS

ROAD CLASS TS-741  
SYMBOL S-41

FUEL - DIESEL OIL  
\* WEIGHTS IN WORKING ORDER  
TOTAL ON DRIVERS 137,600 LBS.  
TOTAL DRY (LIGHT) WT. 132,800 LBS.  
AXLE LOAD 34,400 LBS.

NOTE:  
\* INCLUDES FULL LOAD FUEL  
OIL, LUBR. OIL, WATER, SAND,  
ALL EQUIP. AND 2 MEN.

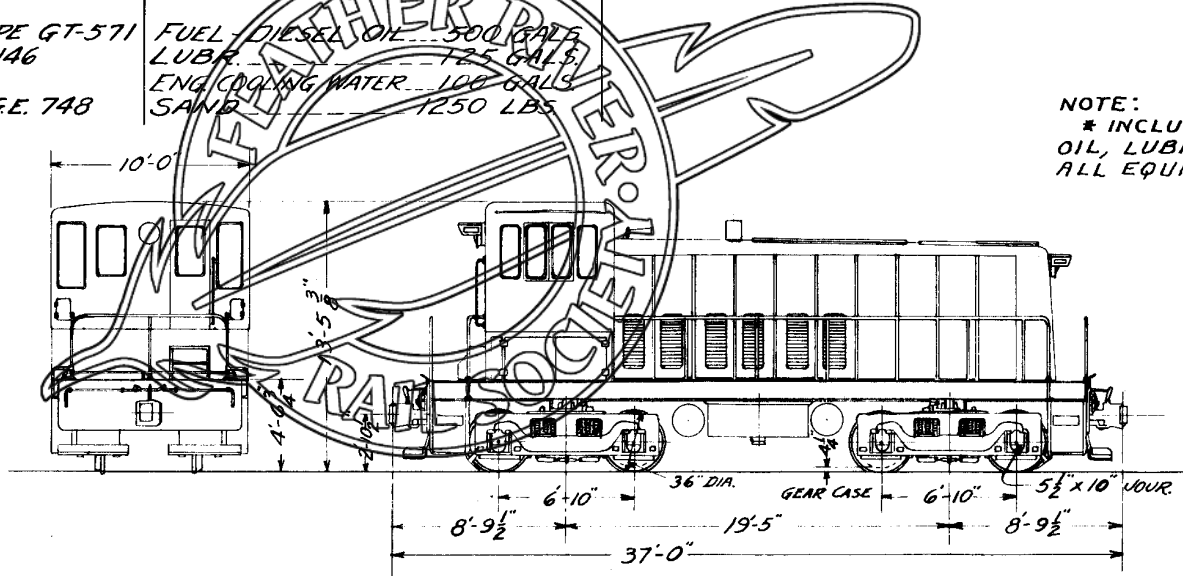

LT. WT. OF TENDER - 89,100 LBS.  
 CAPACITY OF TANK - 10,000 GALS.  
 TOTAL WT. OF TENDER - 172,500 LBS.

**DIESEL TENDER**  
 CONVERTED FROM ENG. CL. 171 TENDERS  
 BY W.P.R.R.  
 A.F.F. 105-50

TENDER Nos. 851 - 853  
 No. OF TENDERS - 3 (8-1-51)

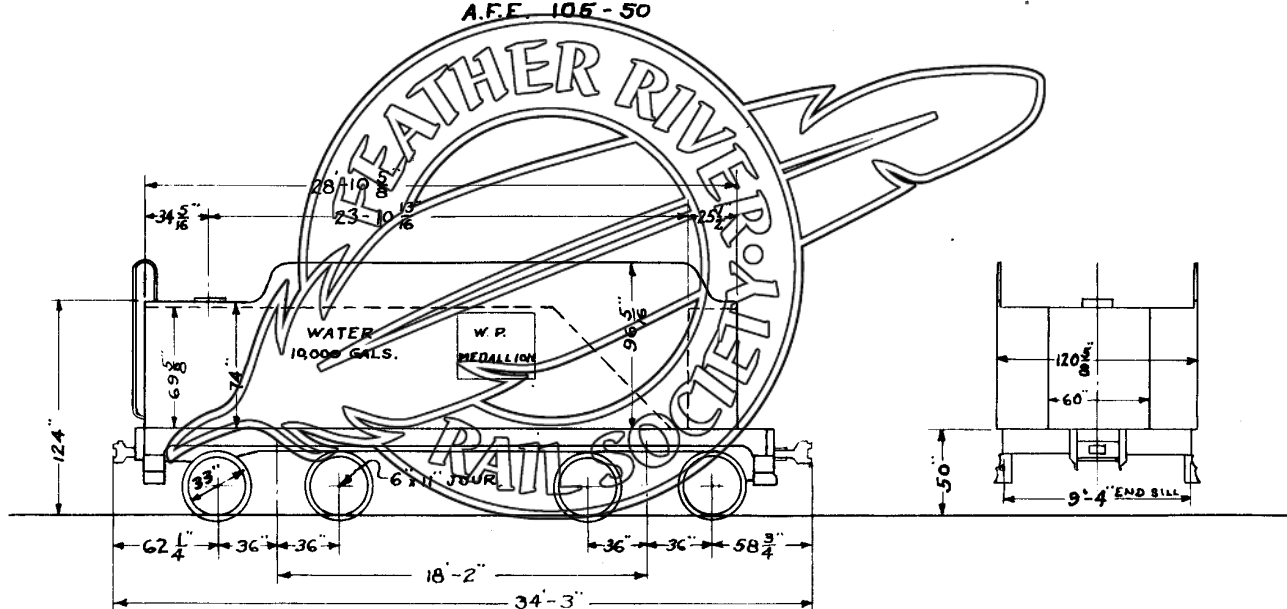

NOS. 21-65. NO. OF ENGS. SEE SHT. 1-B  
 BUILT-ALCO. 1909  
 SPEC. NO. A-3920-B

# CONSOLIDATION 2-8-0

ROAD CLASS 2-1  
 SYMBOL C-43  
 FUEL-OIL

FIREBOX LENGTH, INSIDE	121"	TUBES NUMBER, 2" DIA. 217- 5 1/2" DIA. 96	2074
HEIGHT, FRONT	80 1/2"	LGTH. OVER TUBE SHEET 13'-11"	218
" " BACK	78 1/2"	HEATING SURFACE	2292
WIDTH, TOP, FRONT	72"	FIRE TUBES, SQ. FT.	733
" " BACK	60"	FIREBOX " " "	
" " BOTTOM	40"	TOTAL " " "	
		SUPERHEAT " " "	

AIR PUMP-2-11" OR 1-8 1/2" C.C.  
 BRAKE EQUIPT. ET-6, 3 WIN-2  
 SUPERHEATER TYPE "A"  
 DRAFT GEAR FRICTION  
 REVERSE GEAR ALCO. TYPE "K"

TRACTIVE POWER 43300 LBS  
 FACTOR OF ADHESION 4.24  
 STEAM PRESSURE 200 LBS.  
 MAX. TRACK CURVE 12°

WEIGHTS LOADED ON DRIVERS	184000 LBS
" " ENG. TRUCK	19000 "
ENGINE TOTAL	203000 "
TENDER LOADED	135000 "
ENGINE & TENDER	338000 "
LIGHT WEIGHT, ENGINE	179000 "
" " TENDER	60300 "
AXLE LOAD	46000 "

NOTE - ENGINES NOS. 39, 44 & 59 ARE NOT EQUIPPED WITH SUPERHEATER.

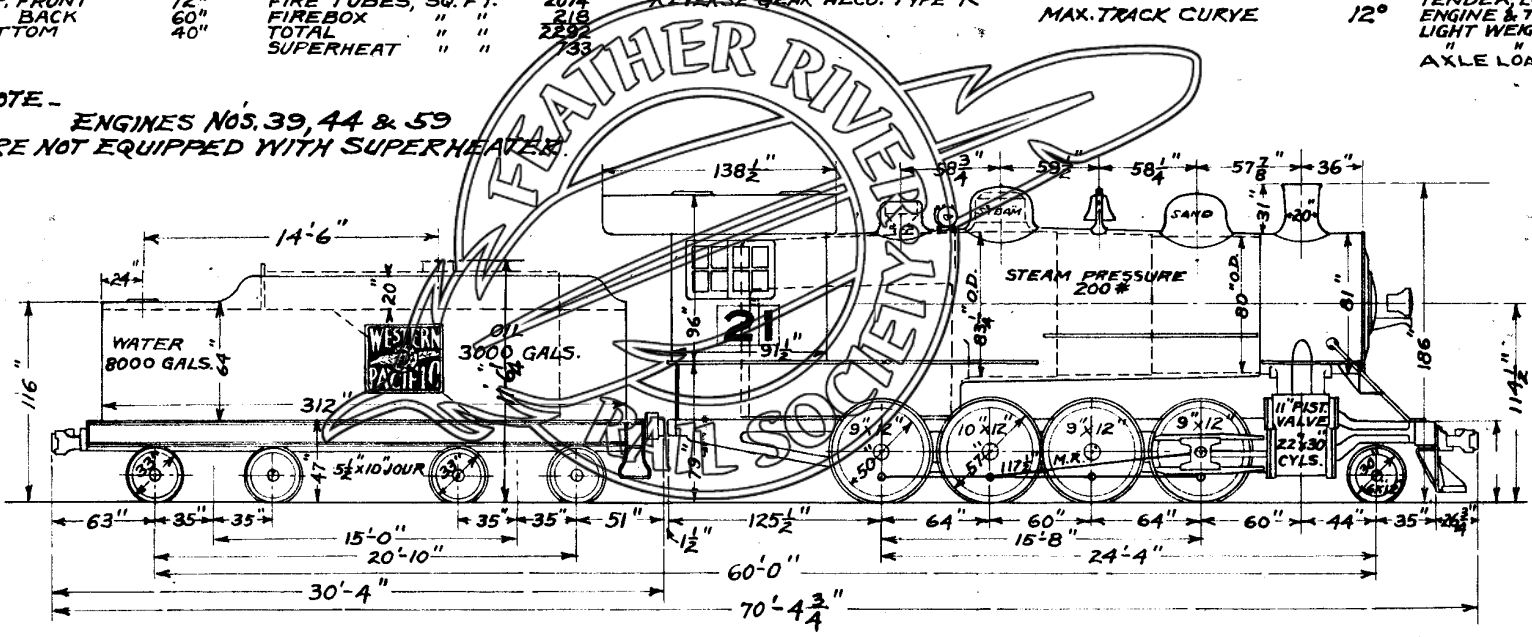

NOS. 163-166. NO. OF ENGS. SEE SHT. 1-B

# SWITCH 0-6-0

ROAD CLASS 163  
SYMBOL S-34  
FUEL, OIL

SPEC. NO. { ENG. 163, SPEC. A-7054-G RETIRED  
ENG. 164, 165, 166. SPEC. A-7054-H

FIRE BOX  
LENGTH, INSIDE 96<sup>3</sup>/<sub>16</sub>"  
HEIGHT, FRONT 71<sup>1</sup>/<sub>2</sub>"  
" BACK 67<sup>1</sup>/<sub>2</sub>"  
WIDTH, TOP, FRONT 61"  
" BACK 61"  
" BOTTOM \*38<sup>1</sup>/<sub>2</sub>"

TUBES  
NUMBER 2" DIA. 182-5<sup>1</sup>/<sub>2</sub> DIA. 24  
LENGTH OVER TUBE SHEET 11'-0"  
HEATING SURFACE  
FIRE TUBES SQ. FT. 1416  
FIRE BOX " " 154  
TOTAL " " 1570  
SUPERHEAT " " 291

AIR PUMP 1-8<sup>1</sup>/<sub>2</sub>"  
BRAKE EQUIP. \*6 ET.  
SUPERHEATER TYPE "A"  
DRAFT GEAR  
REVERSE GEAR MELLIN.

TRACTIVE POWER 34400 LBS.  
FACTOR OF ADHESION 4.6  
STEAM PRESSURE 180 LBS.

WEIGHTS LOADED  
ON DRIVERS 160000 LBS.  
ENGINE TOTAL 160000 "  
TENDER LOADED 102500 "  
ENGINE & TENDER 262500 "  
LIGHT WEIGHT ENGINE 144000 "  
" TENDER 50500 "  
AXLE LOAD 53333 "

MAX. TRACK CURVE 24°

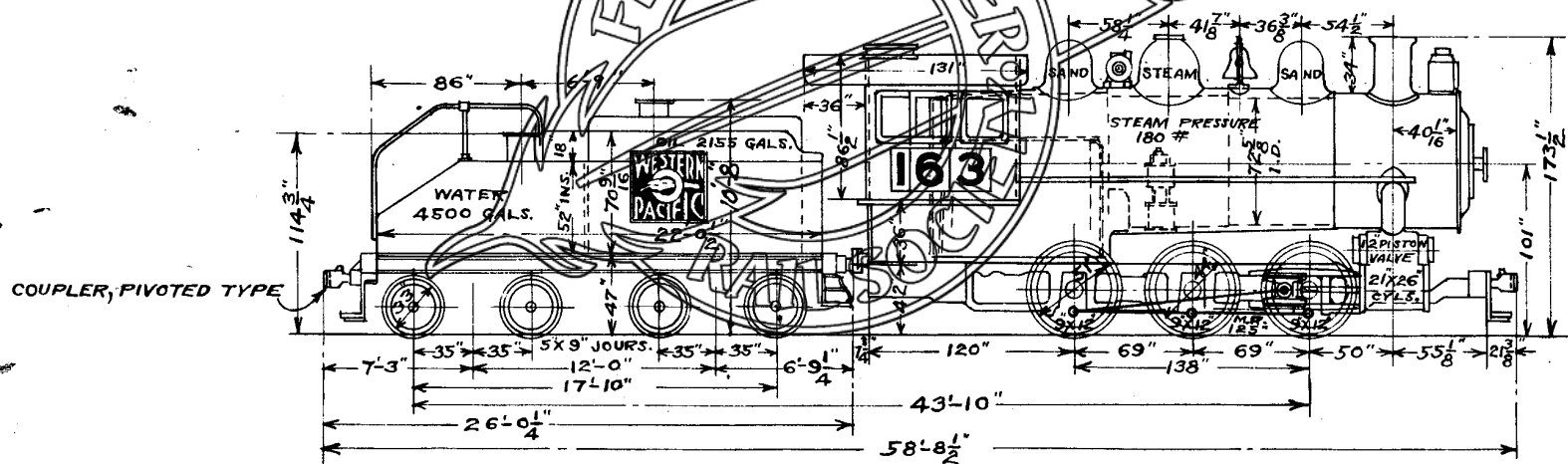

\* - 42" ON ENG. 163 ONLY

NOS. 332-336, NO OF ENGS. SEE SHT. 1-B  
 BUILT-ALCO. 1929  
 SPEC. NO. A-11989-A

# MIKADO 2-8-2

ROAD CLASS 332  
 SYMBOL MK-60-71  
 FUEL - OIL

**FIRE BOX**  
 LENGTH, INSIDE, BOTTOM 120 1/8"  
 COMBUSTION CHAMBER 36"  
 HEIGHT FRONT 89 1/2"  
 " BACK 65"  
 WIDTH, BOTTOM 84 1/4"  
 SYPHONS, FR BX. 2, COMB. CHAM. 1"  
 GRATE AREA 70.3 SQ. FT.

**TUBES**  
 NUMBER 2 1/4 DIA. 213 - 5 1/2 DIA. 45  
 LGTH. OVER TUBE SHEETS 216"  
 HEATING SURFACE  
 FIRE TUBES, SQ. FT. 3407  
 SYPHONS " " 92  
 FIRE BOX " " 28 1/2  
 TOTAL " " 378 1/2  
 SUPERHEAT " " 378

F.W. HEATER ELESKO K-39-A  
 " PUMP " CF-1  
 REVERSE GEAR ALCO TYPE "G"  
 AIR PUMP 1-8 1/2 CROSS COMP.  
 DRAFT GEAR MINER A-79 X B  
 BRAKE EQUIPT. WYSTHSE. ET-6  
 SUPERHEATER TYPE "A"  
 (BOSSER) FRANKLIN C-2

TRACTIVE POWER WITHOUT BOOSTER 60300\*  
 " WITH BOOSTER 71300\*  
 FACTOR OF ADHESION ENGINE 4.1  
 " " ENG. & BOOSTER 4.3  
 STEAM PRESSURE 200 LBS.

MAX. TRACK CURVE 16°

**WEIGHTS LOADED**  
 ON DRIVERS 249000 LBS.  
 " LEAD TRUCK 25500 "  
 " TRAIL " 37500 "  
 ENGINE TOTAL 332000 "  
 TENDER LOADED 267000 "  
 ENG. & TENDER 599000 "  
 LIGHT. WT. ENGINE 296400 "  
 " " TENDER 114300 "  
 AXLE LOAD 62750 "

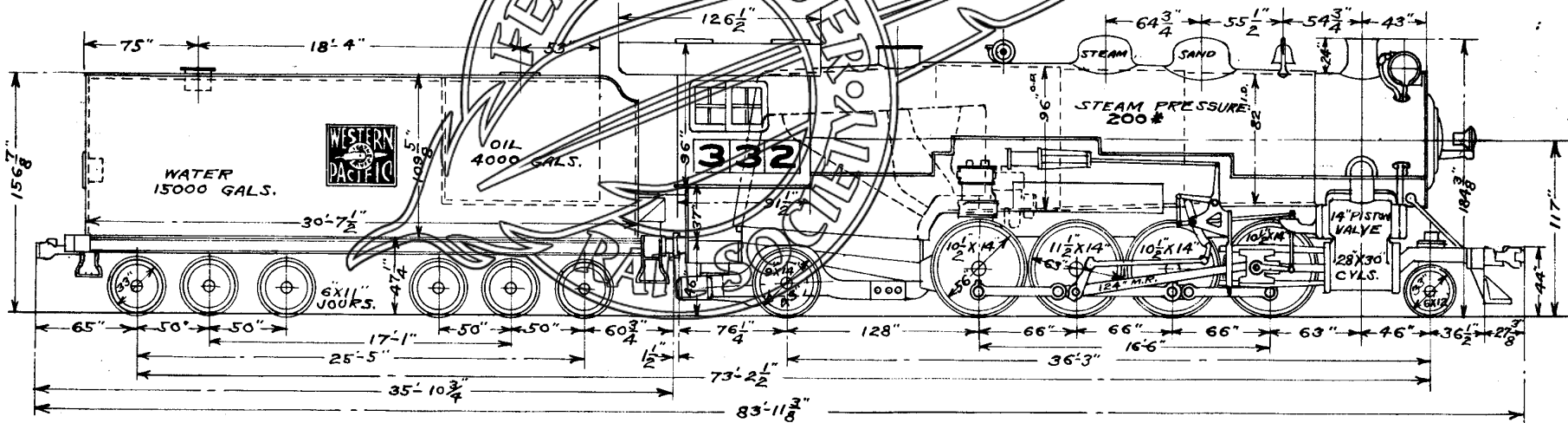

REV. 11-23-46  
 ADDED SYPHONS  
 IN COMB. CHAMBER  
 REV. 10-23-47

Nos. 481-486 No. of ENGS. SEE SH. 1-B  
 BUILT-LIMA LOCO. WKS. INC. 1943.  
 SPEC. No. A-2913.

# 4-8-4 TYPE

ROAD CLASS 481  
 SYMBOL GS-64-77

FIREBOX		TUBES		F.W. HEATER WORTHINGTON 5-SA		TRACTIVE POWER WITHOUT BOOSTER 64200 #		WEIGHTS LOADED	
LENGTH INSIDE BOTTOM	127 1/2"	NUMBER	2 1/4" DIA. 49, 3 1/2" DIA. 198	REVERSE GEAR	ALCO TYPE G.	" WITH BOOSTER	75500	ON DRIVERS	280950 LBS.
COMBUSTION CHAMBER	60"	LENGTH OVER TUBE SHEETS	258"	AIR PUMP	2 - 8 1/2" CROSS COMP.	"	"	LEAD TRUCK	73650 "
HEIGHT FRONT	85 1/2"	HEATING SURFACE	4502	DRAFT GEAR	WAUGH TYPE WMGLE	"	"	TRAILING "	111500 "
" BACK	68 1/2"	FIRE TUBES SQ. FT.	4502	BRAKE EQUIPT.	WESTINGHOUSE ETC.	STEAM PRESSURE	260 LBS.	ENGINE TOTAL	466100 "
WIDTH BOTTOM	102 1/2"	SYPHONS	4	SUPERHEATER	TYPE E			TENDER LOADED	397700 "
SYPHONS, FIREBOX	4	FIREBOX	"	BOOSTER, FRANKLIN	" C-2-5	MAX. TRACK CURVE	18°	ENG. & TEND. "	863800 "
GRATE AREA	90.2 SQ. FT.	TOTAL	"					LIGHT WT. ENGINE	417600 "
		SUPERHEAT	"					" TENDER	153520 "
			2088					AVG. AXLE LOAD	70237 "

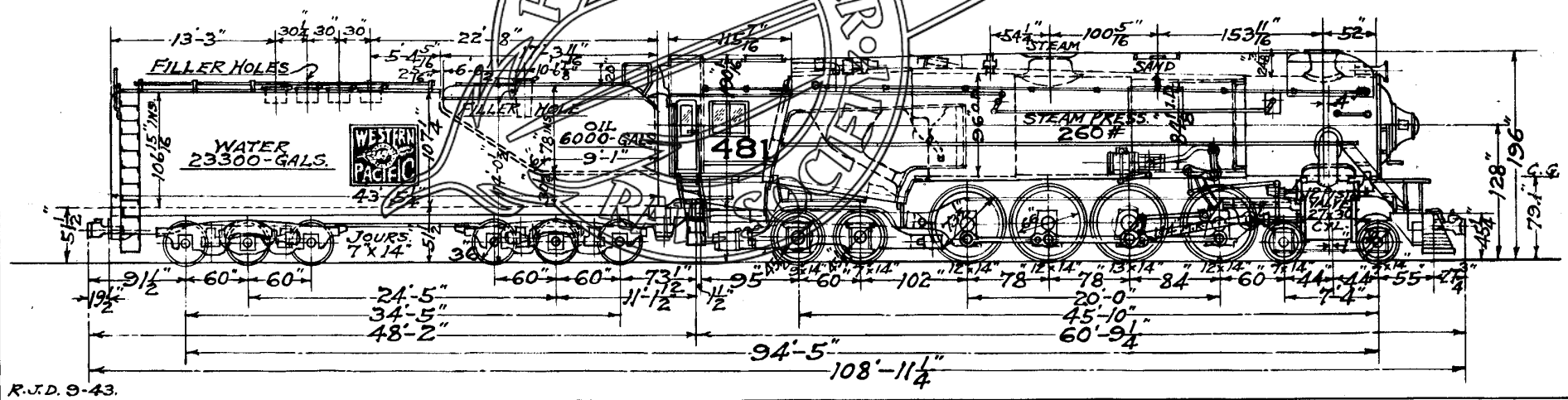

R.J.D. 9-43.



T.S.R.R. No. 132 No. OF ENGS. SEE SH. 1-B  
 BUILT - BALDWIN LOCO. WKS. 1923  
 FORMERLY SIERRA R.R. LOCO. No 32, SPEC. No C-9850.

# PRAIRIE TYPE 2-6-2

ROAD CLASS  
 SYMBOL TF-20

FIRE BOX LENGTH, INSIDE	61 1/2"	TUBES NUMBER 2" DIA. 112, 5" DIA. 18	ONE - 11" AIR PUMP	TRACTIVE POWER	20400 LBS.
HEIGHT, FRONT	60 1/2"	LENGTH OVER TUBE SHEETS 12-3	DRAFT GEAR PIVOT COUPLERS	FACTOR OF ADHESION	4.07
WIDTH, TOP, FRONT	52 1/2"	HEATING SURFACE	BRAKE EQUIP. WEST. AMER. E.T.S. & WM-1-BC	STEAM PRESSURE	180 LBS.
WIDTH, TOP, BACK	51 1/2"	FIRE TUBES SQ. FT.	SUPERHEATER SCHMIDT TYPE	MAX. TRACK CURVE	35°
HEIGHT, BOTTOM	41 1/2"	FIRE BOX TOTAL	VALVE MOTION WALSCHAERT.		
GRATE AREA SQ. FT.	175	SUPERHEAT. " "			

FUEL-OIL

WEIGHTS LOADED

ON DRIVERS	83100 LBS.
" LEAD TRUCK	11400 "
" TRAIL	11700 "
ENGINE TOTAL	106200 "
TENDER LOADED	78586 "
ENGINE & TENDER	184786 "
LIGHT WEIGHT ENG.	
" TEND.	
AVG. AXLE LOAD	27700 "

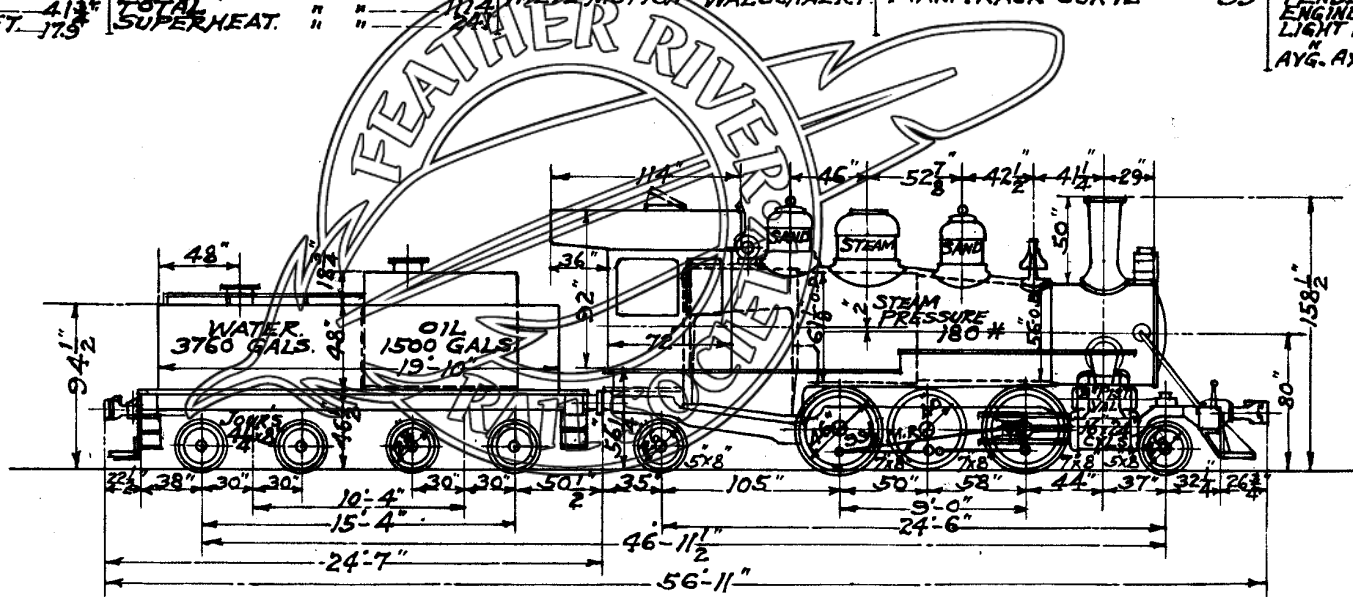

R.J.D. 7-40.